



**TEREX | DEMAG**

**CC 2800-1 | Crawler Crane 600 t Lifting Capacity**



# CC 2800-1

**CRAWLER CRANE**

- ▶ 600 t lifting capacity at 10 m radius
- ▶ Excellent lifting capacities throughout the whole working range
- ▶ Very simple assembly and short rigging time
- ▶ Variable Superlift radius
- ▶ Variable offset of main boom for configuration SW and SWSL
- ▶ Power-Kit for main boom
- ▶ Innovative Demag IC-1 crane control system with touchscreen
- ▶ Improved setup and rigging for boom systems
- ▶ Quadro-Drive on demand

- ▶ 600 t Tragkraft bei 10 m Ausladung
- ▶ Hervorragende Tragfähigkeiten über alle Arbeitsbereiche
- ▶ Enorm vereinfachte Montage und kürzeste Rüstzeiten
- ▶ Variabler Superlift-Radius
- ▶ Variable Vorneigung Hauptausleger für SW und SWSL
- ▶ Hauptausleger-Verstärkungs-Kit
- ▶ Innovative Kransteuerung Demag IC-1 mit Touchscreen
- ▶ Verbesserte Aufrichtemöglichkeiten der Auslegersysteme
- ▶ Quadro-Antrieb optional

- ▶ Capacité de levage de 600 t à 10 m de portée
- ▶ Excellentes capacités de levage dans tous les domaines de travail
- ▶ Assemblages considérablement simplifié et temps de montage réduit
- ▶ Radius variable du Superlift
- ▶ Flèche principale inclinable pour SW et SWSL
- ▶ Kit à fortifier de flèche principale
- ▶ Nouveau système de contrôle Demag IC-1 avec écran tactile
- ▶ Montage amélioré pour les systèmes de flèches
- ▶ Entraînement quadro optionnel

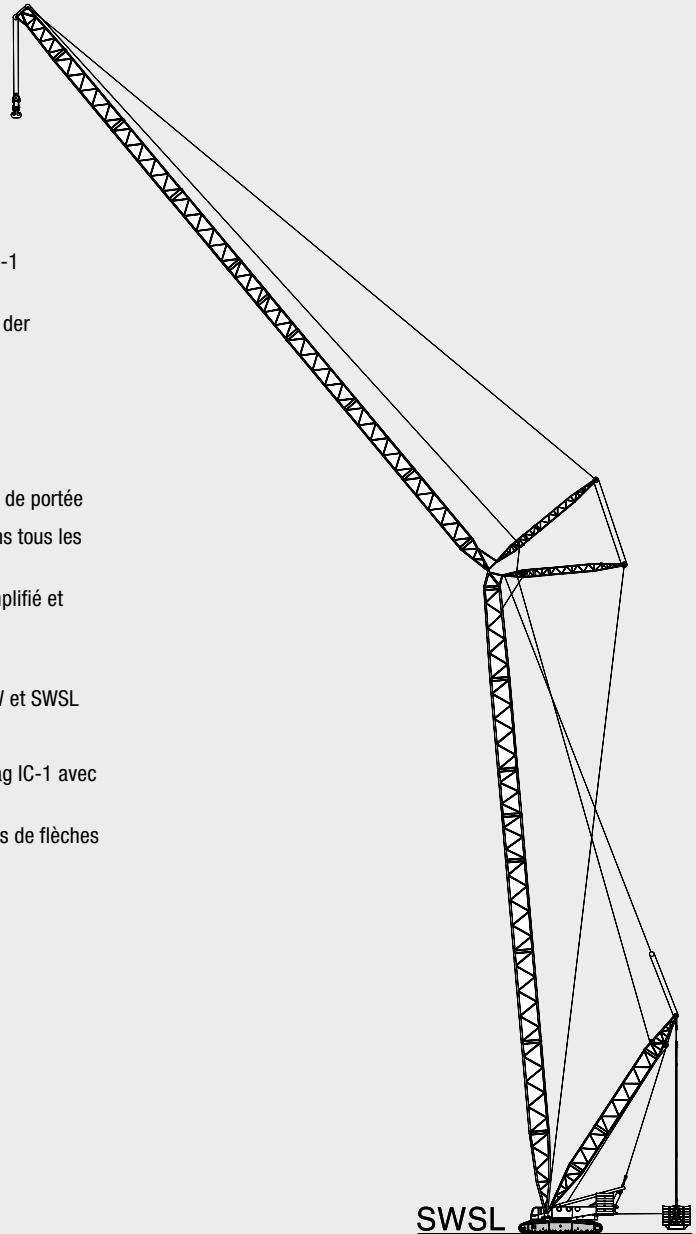

**CONTENTS · INHALT · CONTENU**

Page · Seite · Page:

**Specifications · Technische Daten · Caractéristiques**

Specifications · Technische Daten · Caractéristiques .....	4
Superlift configurations · Superlift-Konfigurationen · Combinaisons Superlift .....	6
Specifications · Technische Daten · Caractéristiques .....	7
Boom combinations · Ausleger-Kombinationen · Combinaisons de flèche .....	10
Erection / lowering · Aufrichten / Ablegen · Monter / déposer .....	12

1

**Main boom · Hauptausleger · Flèche principale**

Working ranges · Arbeitsbereiche · Portées (SH, SH / LH) .....	13
Lifting capacities · Tragfähigkeiten · Capacités de levage (SH, SH / LH) .....	14
Working ranges with Superlift · Arbeitsbereiche mit Superlift · Portées avec Superlift (SSL/HSSL, SSL/LSL) .....	16
Lifting capacities with Superlift · Tragfähigkeiten mit Superlift · Capacités de levage avec Superlift (SSL/HSSL, SSL/LSL) .....	17

2

**Fixed fly jib · Starrer Hilfsausleger · Fléchette fixe**

Working ranges, 10° · Arbeitsbereiche, 10° · Portées, 10° (SH + LF2, SH/LH + LF2) .....	21
Lifting capacities · Tragfähigkeiten · Capacités de levage (SH + LF2, SH/LH + LF2) .....	22
Working ranges with SL, 10° · Arbeitsbereiche mit SL, 10° · Portées avec SL, 10° (SSL + LF2, SSL/LSL + LF2) .....	26
Lifting capacities with SL · Tragfähigkeiten mit SL · Capacités de levage avec SL (SSL + LF2, SSL/LSL + LF2) .....	27

3

**Luffing fly jib · Wippbarer Hilfsausleger · Fléchette à volée variable**

Working ranges · Arbeitsbereiche · Portées (SW) .....	36
Lifting capacities · Tragfähigkeiten, Hauptausleger · Capacités de levage (SW) .....	37
Working ranges · Arbeitsbereiche · Portées (SWSL) .....	44
Lifting capacities with SL · Tragfähigkeiten mit SL · Capacités de levage avec SL (SWSL / SFSL 15° / HSWSL) .....	45

4

**Fixed fly jib · Starrer Hilfsausleger · Fléchette fixe**

Working ranges with SL, 13° · Arbeitsbereiche mit SL, 13° · Portées avec SL, 13° (SFVL / LFVL) .....	58
Lifting capacities with SL · Tragfähigkeiten mit SL · Capacités de levage avec SL (SFVL / LFVL) .....	59

5

**Technical description · Technische Beschreibung · Descriptif technique**

Crawler carrier · Superstructure · Optional equipment .....	60
Boom configurations S and L .....	61
Raupenunterwagen · Oberwagen · Zusatzausrüstung .....	62
Auslegervarianten S und L .....	63
Châssis à chenilles · Partie supérieure · Equipements optionnels .....	64
Configurations de flèche S et L .....	65

6

**Transport example for CC 2800-1**

Transportbeispiel CC 2800-1 · Exemple de transport pour la CC 2800-1 .....	66
--	----

7

**SPECIFICATIONS · TECHNISCHE DATEN · CARACTÉRISTIQUES**
**WORKING SPEEDS (INFINITELY VARIABLE) · ARBEITSGESCHWINDIGKEITEN (STUFENLOS REGELBAR) · VITESSES DE TRAVAIL (RÉGLABLES SANS PALIERS)**

Mechanisms Antriebe Mécanismes	Rope $\varnothing$ Seil- $\varnothing$ $\varnothing$ du câble	Speeds <sup>1)</sup> Geschwindigkeiten <sup>1)</sup> Vitesses <sup>1)</sup>	Single line pull Seilzug je Strang Effort sur brin simple	Length of hoist rope Länge des Hubseils Longueur du câble de levage
Hoist I (H1) Hubwerk I (H1) Treuil de levage I (H1)	28 mm	max. 120 m / min	158 kN / 141 kN <sup>2)</sup>	900 m
Hoist II (H2) Hubwerk II (H2) Treuil de levage II (H2)	28 mm	max. 120 m / min	158 kN / 141 kN <sup>2)</sup>	900 m
Boom derricking (W2) Wippwerk Hauptausleger (W2) Variation de flèche (W2)	28 mm	max. 120 m / min		
Boom hoist (E) Einziehwerk (E) Relevage de flèche (E)	30 mm	max. 52 m / min		
Jib luffing (W1) Wippwerk Hilfsausleger (W1) Variation de volée (W1)	28 mm	max. 120 m / min		
Slewing (rpm) Drehwerk (U/min) Orientation (tr/mn)		0,7		

1) top layer · oberste Lage · couche supérieure

2) without / with reeving effect considered · Angabe ohne / mit Wirkungsgrad der Einscherung · sans / avec effort de mouflage

**BASIC CRANE DIMENSIONS · HAUPTABMESSUNGEN · DIMENSIONS DE LA GRUE DE BASE**

Basic crane dimensions with standard Superlift attachment  
 Hauptabmessungen mit serienmäßiger Superlifteinrichtung  
 Dimensions de la grue de base avec Superlift de série

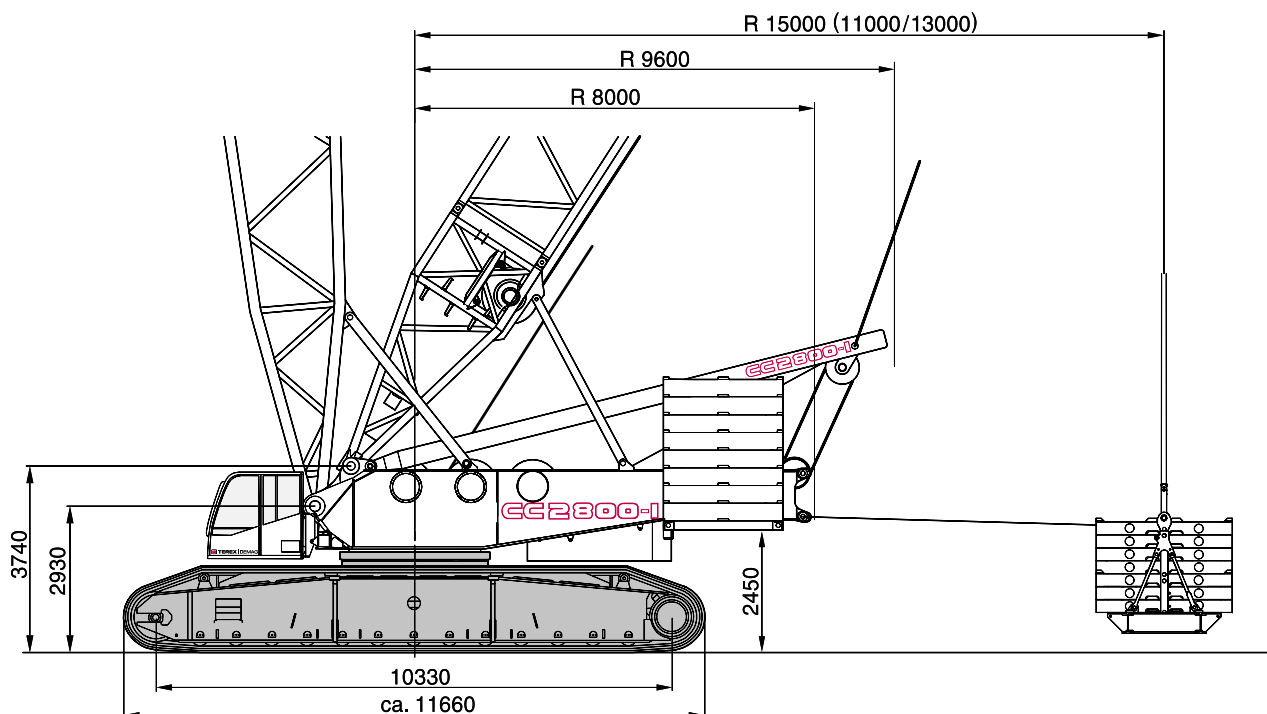

**SPECIFICATIONS · TECHNISCHE DATEN · CARACTÉRISTIQUES**

**CARRIER PERFORMANCE WITH STANDARD DRIVE · FAHRLEISTUNGEN BEI STANDARD-ANTRIEB · PERFORMANCES DU PORTEUR AU ENTRAÎNEMENT STANDARD**

1 <sup>st</sup> gear 1. Gang 1 <sup>ère</sup> vitesse	0-0,6 km/h
2 <sup>nd</sup> gear 2. Gang 2 <sup>ème</sup> vitesse	0-1,2 km/h

**HOOK BLOCKS · UNTERFLASCHEN · CROCHET-MOUFLE**

Type Typ Type	Possible load Mögliche Traglast Charge possible	Number of sheaves Anzahl der Rollen Nombre de poulies	Number of lines Strangzahl Nombre de brins	Weight Gewicht Poids	„D“
2 x 300	600 t 247 t	2 x 11 11	2 x 22 17	10,4 t – 12,0 t 7,1 t – 7,9 t	5,00 m 5,40 m
2 x 200	400 t 196 t	2 x 7 7	2 x 14 13	8,2 t – 10,0 t 5,3 t – 6,2 t	5,00 m 5,40 m
160	160 t	5	11	3,3 t – 4,8 t	4,30 m
110	110 t	3	7	1,9 t – 3,6 t	4,30 m
50	50 t	1	3	2,8 t	4,00 m
16	16 t	—	1	0,9 t	3,00 m

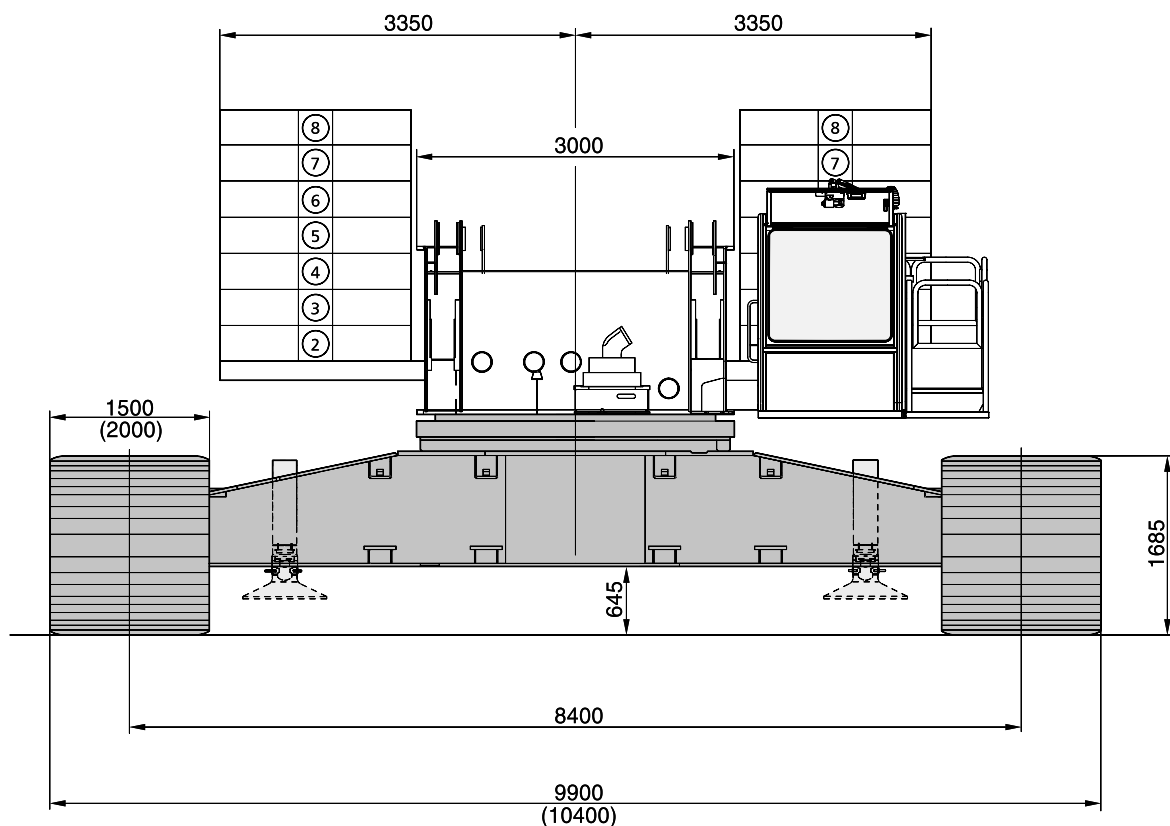

**SUPERLIFT CONFIGURATIONS · SUPERLIFT-KONFIGURATIONEN ·  
COMBINAISONS SUPERLIFT**

**STANDARD-SL**  11, 13, 15 m

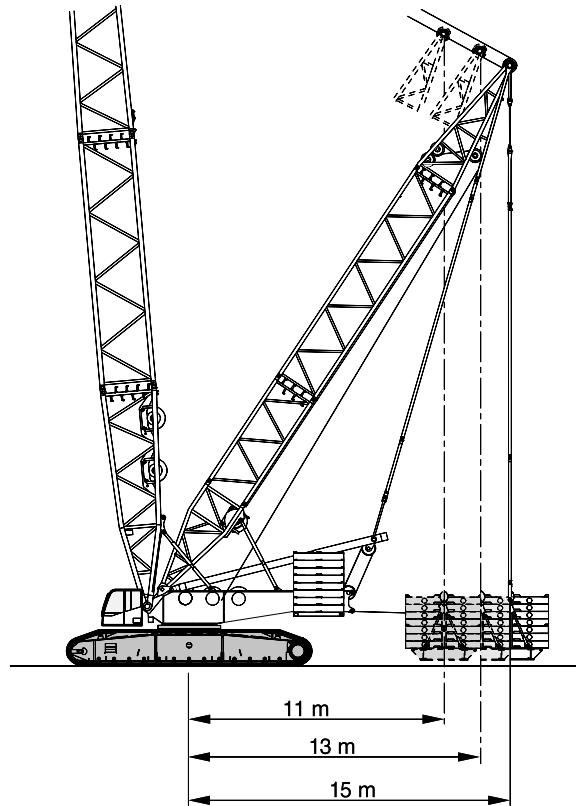

**TELE-SL**  13-17 m

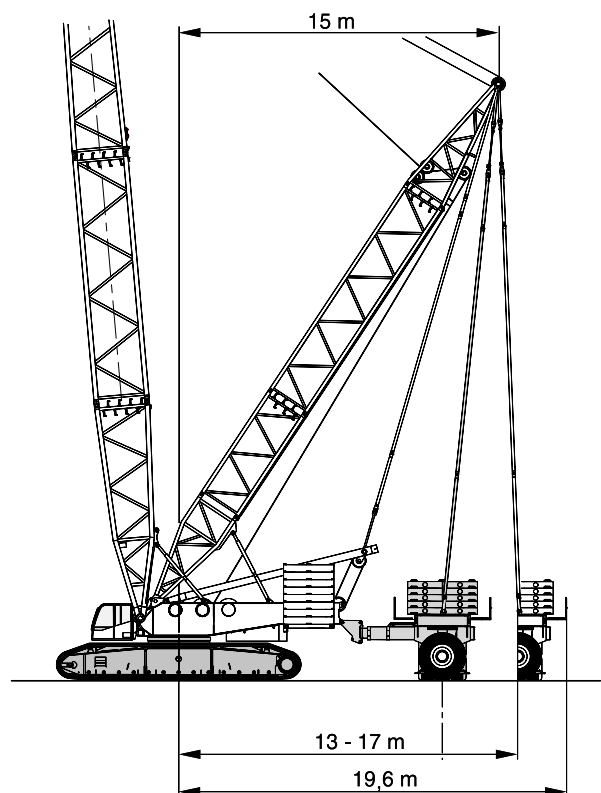
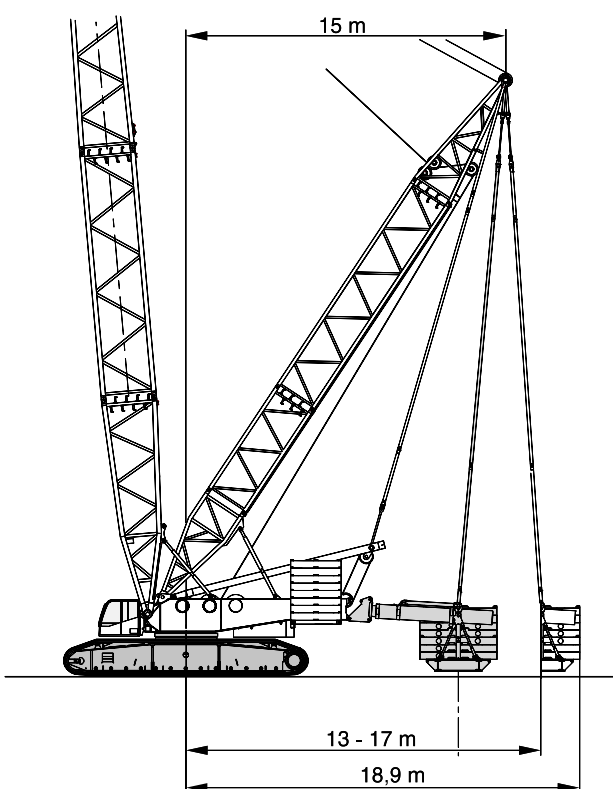

**SPECIFICATIONS · TECHNISCHE DATEN · CARACTÉRISTIQUES**

**WEIGHTS · GEWICHTE · POIDS**

Total weight incl. counterweight 160 t, 24 m SH boom and hook block Gesamtgewicht einschl. Gegengewicht 160 t, 24 m Hauptausleger SH und Unterflasche Poids total avec contrepoids 160 t, flèche SH 24 m et crochet-moufle	360 t
Superstructure (with three drums, A-frame, reeving drum and boom backstops) Oberwagen (mit drei Winden, A-Bock, Einscherwinde und Rückfallzylinder) Partie supérieure (avec trois treuils, chevalet, tambour de mouflage et retenues de flèche)	55 t
Superstructure (without drums H1/H2, reeving winch, boom backstops and A-frame) incl. part of quick-connection Oberwagen (ohne Winden H1/H2, Einscherwinde, Rückfallzylinder und A-Bock) und Anteil Quick-Connection Partie supérieure (sans treuils H1/H2, tambour de mouflage, retenues de flèche et chevalet) incl. partie de connexion rapide	36,8 t
Carbody / Carbody with assembly jacks Mittelstück / Mittelstück mit Montageabstützung Partie centrale / Partie centrale avec vérins de montage	26 / 28 t
Crawlers with standard drive (option: quadro drive) Rauhen mit Standard-Antrieb (Option: Quadro-Antrieb) Chenilles avec entraînement standard (en option: quadro-moteur)	2 x 44 t (2 x 48 t)
Counterweight Gegengewicht Contrepoids	160 t

**GROUND PRESSURE · BODENDRUCK · PRESSION AU SOL**

Ground pressure, based on 360 t total weight Bodendruck bei 360 t Gesamtgewicht Pression au sol, avec un poids total de 360 t	14 N/cm <sup>2</sup>
---	----------------------

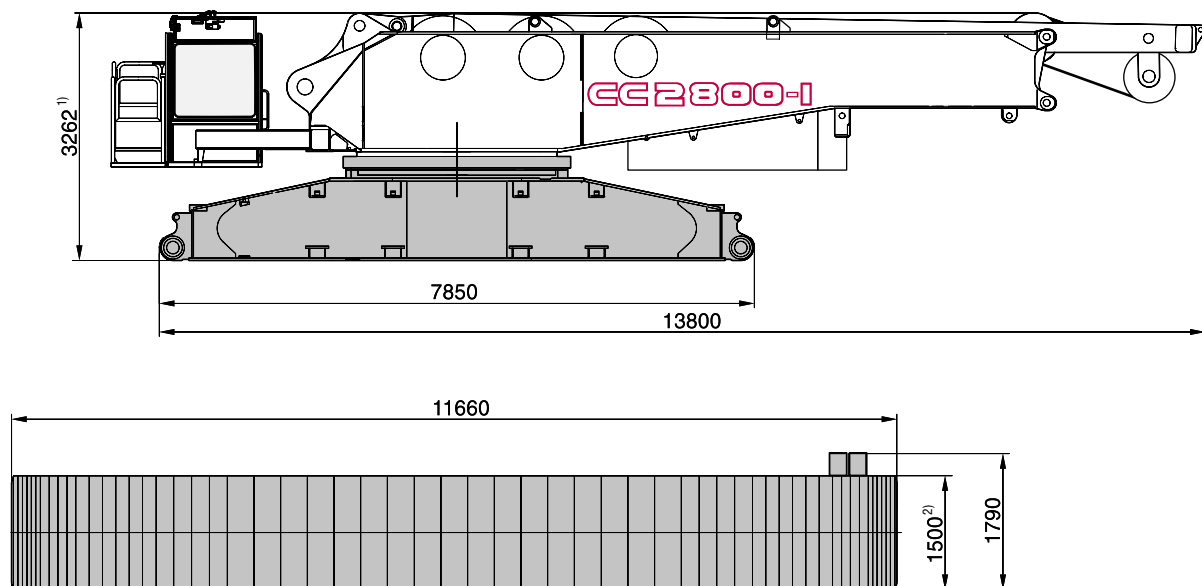

<sup>1)</sup> With quick-connection 3460 mm · mit Schnellverbindung 3460 mm · avec connexion rapide 3460 mm

<sup>2)</sup> optional 2000 mm · Option 2000 mm · option 2000 mm

**SPECIFICATIONS · TECHNISCHE DATEN · CARACTÉRISTIQUES**

Counterweights on upper  
Gegengewichte Oberwagen  
Contrepoids sur partie  
tournante

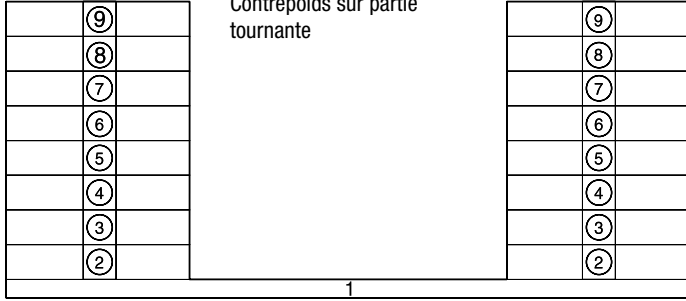

Central ballast (ZB)  
Zentralballast (ZB)  
Lest central (ZB)

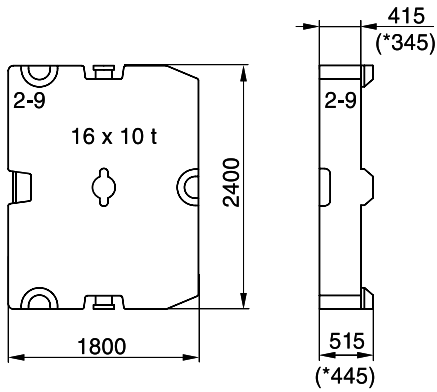
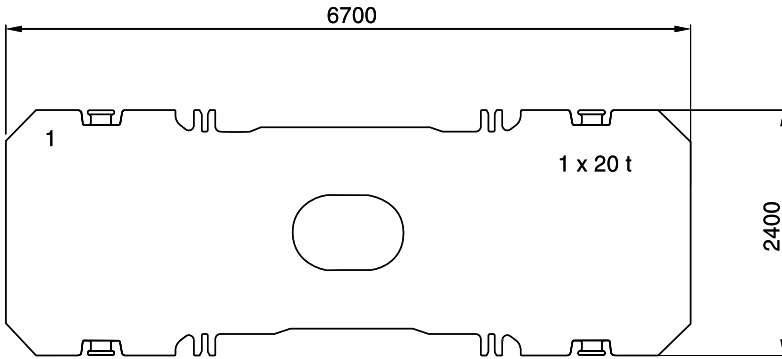
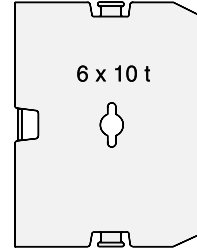

\* optional · Option · option

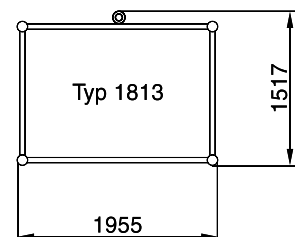
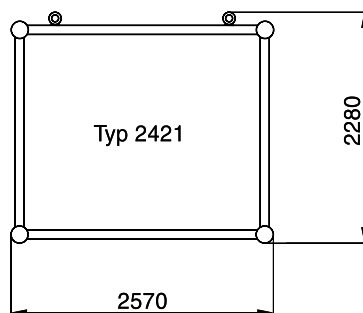
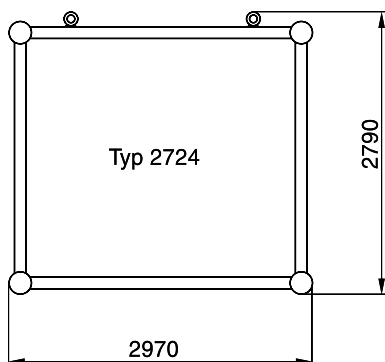





## KEY · ZEICHENERKLÄRUNG · LÉGENDE

 Track · Spur · Voie

 Counterweight + central ballast (ZB) · Gegengewicht + Zentralballast (ZB) · Contrepoids + lest central (ZB)

 Superlift counterweight · Superlift-Gegengewicht · Contrepoids Superlift

 Superlift radius · Superlift-Radius · rayon Superlift

 Load radius · Lastradius · Portée

 Main boom · Hauptausleger · Flèche principale

 Fly jib · Hilfsausleger · Fléchette

 Main boom angle · Hauptauslegerwinkel · Jarret de flèche principale

 Fly jib angle · Hilfsauslegerwinkel · Jarret de fléchette

„D“ 

S: heavy · schwer · lourd

L: light · leicht · léger

H: Main boom · Hauptausleger · Flèche principale

W: Luffing fly jib · Wippbarer Hilfsausleger · Fléchette à volée variable

F: Fixed fly jib · Starrer Hilfsausleger · Fléchette fixe

SL: Superlift

SGL: Heavy base length · Schwere Grundlänge · Longueur de base lourde

**BOOM COMBINATIONS · AUSLEGER-KOMBINATIONEN · COMBINAISONS DE FLÛCHE**

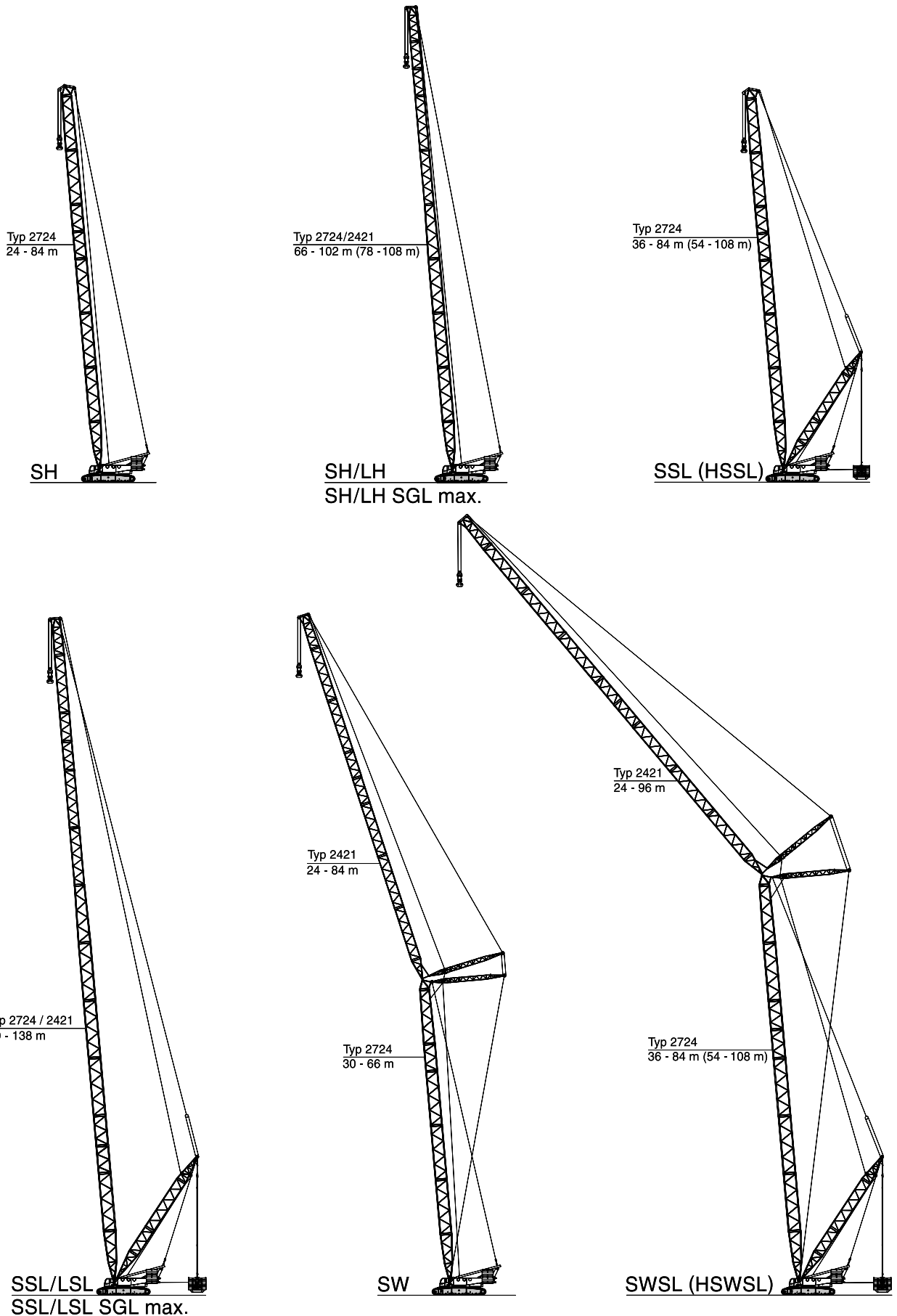

**BOOM COMBINATIONS · AUSLEGER-KOMBINATIONEN · COMBINAISONS DE FLÈCHE**

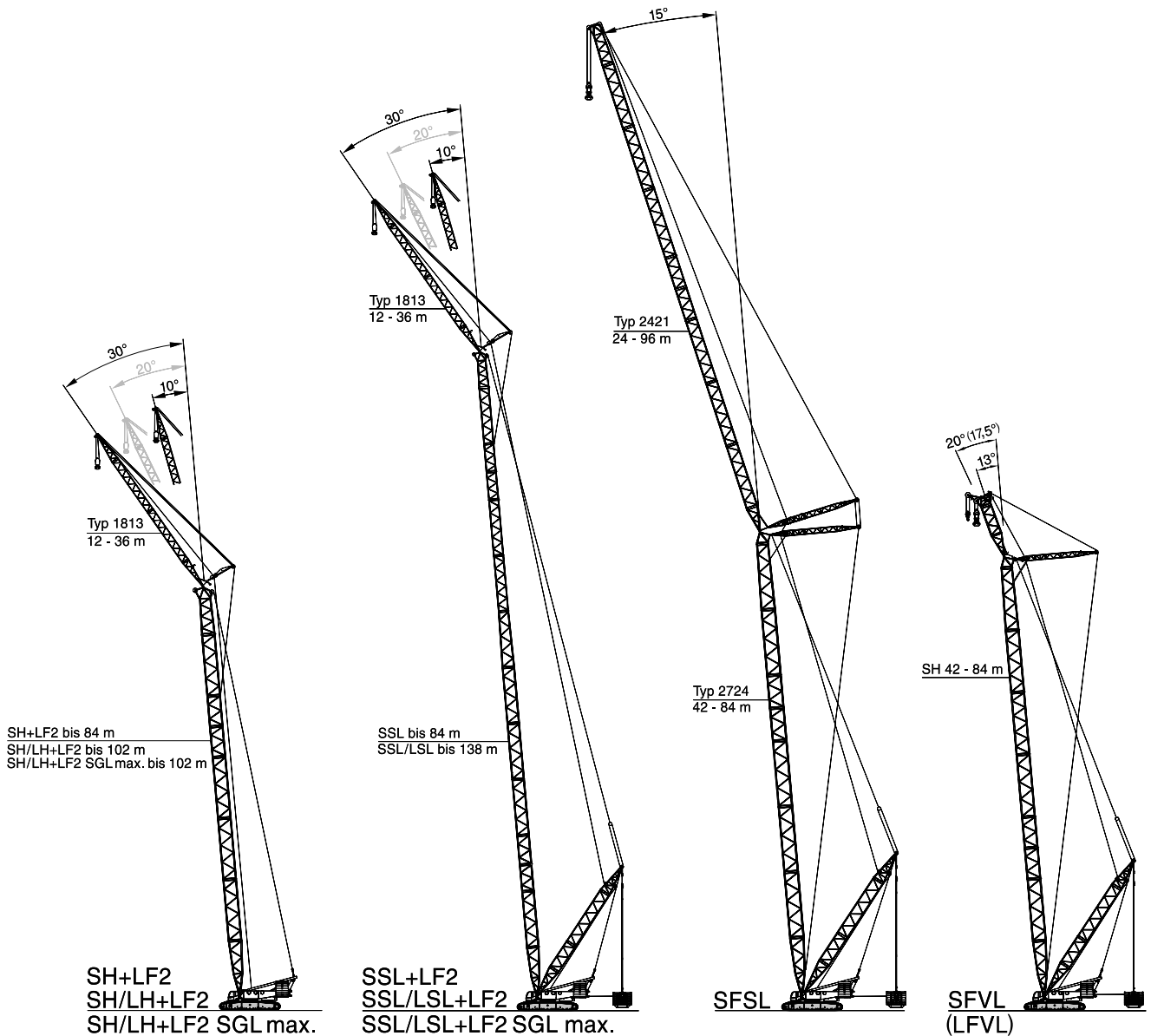

Special combinations available on request!  
 Sonder-Kombinationen auf Anfrage!  
 Combinaisons specials sur demande!

SFVL: Configuration with 600 t heavy-duty head  
 Ausführung mit 600 t Schwerlastkopf  
 Configuration avec tête de la flèche poids-lourd de 600 t

LFVL: Fitted with 300 t jib top section (load charts on request)  
 Ausführung mit 300 t Hilfsauslegerspitze (Tabellen auf Anfrage)  
 Equipée avec tête de la fléchette de 300 t (charges sur demande)

**ERECTION / LOWERING OF THE CC 2800-1 BOOM SYSTEMS TO THE GROUND**  
**AUFRICHTEN / ABLEGEN DER CC 2800-1 AUSLEGERSYSTEME**  
**MONTÉE / PLACEMENT SUR SOL DES SYSTÈMES DE FLÈCHE DE LA CC 2800-1**

☰ 160-180 t    ZB 0-60 t    ↗ 11-15 m

Boom combination Auslegervariante Combinaison de flèche	Fly jib Hilfsausleger Fléchette (m)	Main boom · Hauptausleger · Flèche principale																						
		m	24	30	36	42	48	54	60	66	72	78	84	90	96	102	108	114	120	126	132	138		
<b>SH</b>			X	X	X	X	X	X	X	X	(X)	(X)	[X]	-	-	-	-	-	-	-	-	-	-	
<b>SH/LH</b>			-	-	-	-	-	-	-	X	X	X	X	(X)	[X]	[X]	-	-	-	-	-	-	-	
<b>SH/LH SGLmax.</b>			-	-	-	-	-	-	-	-	-	X	[X]	[X]	[X]	[X]	-	-	-	-	-	-	-	
<b>SW</b>	24		-	X	X	X	X	(X)	[X]	[X]	-	-	-	-	-	-	-	-	-	-	-	-	-	
	30		-	X	X	X	X	(X)	[X]	[X]	-	-	-	-	-	-	-	-	-	-	-	-	-	
	36		-	X	X	X	X	(X)	[X]	[X]	-	-	-	-	-	-	-	-	-	-	-	-	-	
	42		-	X	X	X	X	(X)	[X]	[X]	-	-	-	-	-	-	-	-	-	-	-	-	-	
	48		-	X	X	X	X	(X)	[X]	[X]	-	-	-	-	-	-	-	-	-	-	-	-	-	
	54		-	X	X	X	X	(X)	[X]	[X]	-	-	-	-	-	-	-	-	-	-	-	-	-	
	60		-	X	X	X	X	(X)	[X]	[X]	-	-	-	-	-	-	-	-	-	-	-	-	-	
	66		-	X	X	X	X	(X)	[X]	[X]	-	-	-	-	-	-	-	-	-	-	-	-	-	-
	72		-	X	X	X	X	(X)	[X]	[X]	-	-	-	-	-	-	-	-	-	-	-	-	-	-
78		-	X	X	X	X	(X)	[X]	[X]	-	-	-	-	-	-	-	-	-	-	-	-	-	-	
84		-	X	X	X	X	(X)	[X]	[X]	-	-	-	-	-	-	-	-	-	-	-	-	-	-	
<b>SH+LF2</b>	12		-	X	X	X	X	X	X	X	(X)	[X]	-	-	-	-	-	-	-	-	-	-	-	
<b>SH/LH+LF2</b>	12		-	-	-	-	-	-	-	X	X	(X)	(X)	[X]	[X]	[X]	-	-	-	-	-	-	-	
<b>SH/LH SGLmax. +LF2</b>	12		-	-	-	-	-	-	-	-	-	[X]	[X]	[X]	[X]	-	-	-	-	-	-	-	-	
<b>SSL</b>			-	-	0	0	0	0	0	0	0	20	30	-	-	-	-	-	-	-	-	-	-	
<b>HSSL</b>			-	-	-	-	-	0	0	0	10	25	50	55	80	100	120	-	-	-	-	-	-	
<b>SSL/LSL</b>			-	-	-	-	-	-	-	-	-	-	-	60	75	85	105	125	140	160	165	185		
<b>SSL/LSL SGLmax.</b>			-	-	-	-	-	-	-	-	-	-	10	30	50	70	90	115	135	160	190	220		
<b>LFVL</b>			-	-	-	0	0	20	45	65	95	120	140	-	-	-	-	-	-	-	-	-	-	
<b>SFVL</b>			-	-	-	5	25	40	65	80	105	125	150	-	-	-	-	-	-	-	-	-	-	
<b>SWSL/SFSL</b>	24		-	-	0	0	10	35	60	85	110	125	150	-	-	-	-	-	-	-	-	-	-	
	30		-	-	0	0	10	35	65	85	115	140	155	-	-	-	-	-	-	-	-	-	-	
	36		-	-	0	0	0	25	55	85	115	145	175	-	-	-	-	-	-	-	-	-	-	
	42		-	-	0	0	0	15	50	80	115	145	165	-	-	-	-	-	-	-	-	-	-	
	48		-	-	0	0	0	10	40	70	105	130	165	-	-	-	-	-	-	-	-	-	-	
	54		-	-	0	0	0	15	35	65	90	125	160	-	-	-	-	-	-	-	-	-	-	
	60		-	-	0	0	0	20	40	60	85	115	155	-	-	-	-	-	-	-	-	-	-	
	66		-	-	0	0	0	20	45	65	90	115	140	-	-	-	-	-	-	-	-	-	-	
	72		-	-	0	0	5	25	50	70	95	120	145	-	-	-	-	-	-	-	-	-	-	
78		-	-	0	0	10	30	50	75	100	125	150	-	-	-	-	-	-	-	-	-	-		
84		-	-	0	0	10	30	55	80	105	130	155	-	-	-	-	-	-	-	-	-	-		
90		-	-	0	0	15	35	60	80	105	130	160	-	-	-	-	-	-	-	-	-	-		
96		-	-	5	0	15	40	60	85	110	135	165	-	-	-	-	-	-	-	-	-	-		
<b>SSL+LF2</b>	12		-	-	0	0	0	0	0	0	5	25	-	-	-	-	-	-	-	-	-	-	-	
<b>HSSL+LF2</b>	12		-	-	-	-	0	0	0	0	10	35	50	75	95	120	-	-	-	-	-	-	-	
<b>SSL/LSL+LF2</b>	12		-	-	-	-	-	-	-	-	-	-	40	55	75	85	105	120	140	160	175			
<b>SSL/LSL SGLmax. +LF2</b>	12		-	-	-	-	-	-	-	-	5	25	50	70	100	130	160	190	215	250	285			

**Remarks · Bemerkungen · Remarques**

X without assisting equipment · ohne Zusatzausrüstung · sans équipement aditionnel

(X) idler wheel supported · unterbautes Leitrad · roue directrice avec support

[X] with additional side jack · mit seitlicher Zusatzabstützung · avec support latéral aditionnel

Values for LF with 10° jib offset; values may differ for other offsets · Werte für LF mit 10° Vorneigung; für andere Vorneigungen ergeben sich geringfügige Abweichungen · Valeurs LF avec inclinaison 10 degrés, pour d'autres inclinaisons de petites différences sont possibles.

All Superlift combinations can be erected or lowered to the ground without assisting equipment. The stated numbers represent the necessary SL-counterweight in [t]. · Alle Varianten mit Superlift können ohne Zusatzausrüstung aufgerichtet bzw. abgelegt werden. Die angegebenen Zahlenwerte entsprechen dem notwendigen SL-Ballast in [t]. · Montée et dépose sur sol de toutes les combinaisons avec SL sans équipement aditionnel. Les valeurs indiquées correspondent au balast superlift [en t.] nécessaire.

**SH, SH/LH** WORKING RANGES · ARBEITSBEREICHE ·  
 PORTÉES

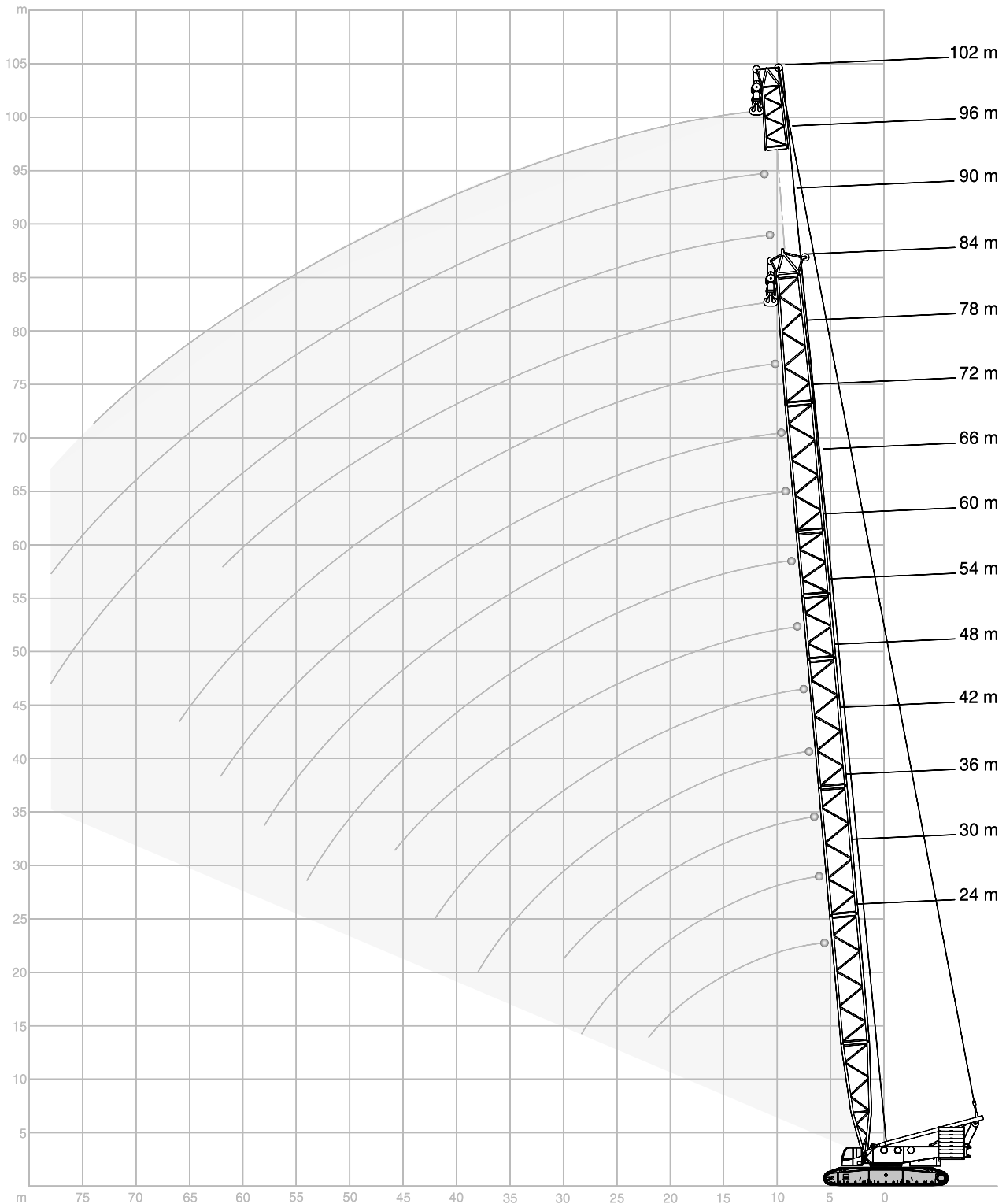



## SH LIFTING CAPACITIES · TRAGFÄHIGKEITEN · CAPACITÉS DE LEVAGE

180 t + 60 t ZB    8,40 m    360°    DIN/ISO

m	Lifting Capacity (t)												m
	24,0 m	30,0 m	36,0 m	42,0 m	48,0 m	54,0 m	60,0 m	66,0 m	72,0 m	78,0 m	84,0 m		
6	600,0	-	-	-	-	-	-	-	-	-	-	-	6
7	561,0	554,0	567,0	-	-	-	-	-	-	-	-	-	7
8	506,0	502,0	499,0	496,0	494,0	-	-	-	-	-	-	-	8
9	410,0	408,0	407,0	406,0	405,0	404,0	404,0	-	-	-	-	-	9
10	337,0	335,0	334,0	332,0	331,0	330,0	330,0	329,0	301,0	-	-	-	10
12	247,0	245,0	243,0	241,0	240,0	239,0	239,0	238,0	237,0	236,0	212,0	-	12
14	193,0	191,0	190,0	188,0	186,0	185,0	185,0	184,0	183,0	182,0	181,0	-	14
16	158,0	156,0	154,0	152,0	151,0	150,0	149,0	148,0	147,0	147,0	145,0	-	16
18	133,0	131,0	129,0	127,0	126,0	125,0	124,0	123,0	122,0	121,0	120,0	-	18
20	115,0	113,0	111,0	109,0	107,0	106,0	105,0	104,0	103,0	102,0	101,0	-	20
22	101,0	98,5	96,5	94,5	93,0	91,5	90,5	89,5	88,5	88,0	86,0	-	22
24	-	87,5	85,0	83,0	81,5	80,0	79,0	78,0	77,0	76,0	74,5	-	24
26	-	78,0	76,0	73,5	72,0	70,5	69,5	68,5	67,5	66,5	65,0	-	26
28	-	70,5	68,0	66,0	64,0	63,0	61,5	60,5	59,5	58,5	57,0	-	28
30	-	-	62,0	59,5	57,5	56,5	55,0	54,0	53,0	52,0	50,0	-	30
34	-	-	-	49,5	47,5	46,1	44,8	43,6	42,4	41,2	39,1	-	34
38	-	-	-	42,1	39,9	38,3	36,7	35,2	33,8	32,6	30,5	-	38
42	-	-	-	-	34,1	31,9	30,2	28,7	27,2	25,9	23,8	-	42
46	-	-	-	-	-	27,0	25,1	23,4	21,9	20,6	18,4	-	46
50	-	-	-	-	-	-	21,0	19,3	17,6	16,2	14,0	-	50
54	-	-	-	-	-	-	17,8	15,9	14,1	12,6	10,4	-	54
58	-	-	-	-	-	-	-	13,2	11,2	9,7	7,4	-	58
62	-	-	-	-	-	-	-	-	8,9	7,2	-	-	62
66	-	-	-	-	-	-	-	-	-	5,2	-	-	66
70	-	-	-	-	-	-	-	-	-	-	-	-	70

160 t    8,40 m    360°    DIN/ISO

m	Lifting Capacity (t)												m
	24,0 m	30,0 m	36,0 m	42,0 m	48,0 m	54,0 m	60,0 m	66,0 m	72,0 m	78,0 m	84,0 m		
7	424,0	467,0	508,0	-	-	-	-	-	-	-	-	-	7
8	405,0	431,0	430,0	428,0	428,0	-	-	-	-	-	-	-	8
9	339,0	337,0	336,0	335,0	334,0	333,0	333,0	-	-	-	-	-	9
10	278,0	276,0	275,0	273,0	272,0	271,0	271,0	270,0	268,0	-	-	-	10
12	203,0	201,0	199,0	198,0	196,0	196,0	195,0	194,0	193,0	193,0	191,0	-	12
14	159,0	157,0	155,0	153,0	152,0	151,0	150,0	149,0	148,0	148,0	146,0	-	14
16	129,0	127,0	125,0	124,0	122,0	121,0	120,0	119,0	118,0	118,0	116,0	-	16
18	109,0	107,0	105,0	103,0	101,0	100,0	99,5	98,5	97,5	96,5	95,0	-	18
20	93,5	91,5	89,5	87,5	86,0	84,5	83,5	82,5	82,0	81,0	79,5	-	20
22	82,0	79,5	77,5	75,5	73,5	72,5	71,5	70,5	69,5	68,5	67,0	-	22
24	-	70,0	68,0	65,5	64,0	63,0	62,0	61,0	60,0	59,0	57,0	-	24
26	-	62,5	60,0	58,0	56,5	55,0	54,0	53,0	52,0	51,0	49,4	-	26
28	-	56,5	54,0	51,5	50,0	48,7	47,6	46,5	45,5	44,4	42,4	-	28
30	-	-	48,8	46,4	44,6	43,3	42,1	40,8	39,6	38,5	36,4	-	30
34	-	-	-	38,1	36,1	34,4	32,9	31,5	30,2	29,0	27,0	-	34
38	-	-	-	32,0	29,5	27,6	25,9	24,5	23,1	21,9	19,8	-	38
42	-	-	-	-	24,5	22,4	20,6	19,1	17,6	16,3	14,2	-	42
46	-	-	-	-	-	18,4	16,4	14,8	13,2	11,9	9,7	-	46
50	-	-	-	-	-	-	13,1	11,3	9,7	8,3	6,1	-	50
54	-	-	-	-	-	-	-	10,6	8,6	6,8	5,3	-	54
58	-	-	-	-	-	-	-	-	6,5	-	-	-	58

**SH/LH LIFTING CAPACITIES · TRAGFÄHIGKEITEN ·**  
**CAPACITÉS DE LEVAGE**

8,4 m 360° DIN/ISO

m	66 m			72 m			78 m			84 m		
	SH/LH		SH/LH SGLmax.	SH/LH		SH/LH SGLmax.	SH/LH		SH/LH SGLmax.	SH/LH		SH/LH SGLmax.
	160 t	180 t+60 tZB		160 t	180 t+60 tZB		160 t	180 t+60 tZB		160 t	180 t+60 tZB	
9	298,0	298,0	-	-	-	-	-	-	-	-	-	-
10	276,0	298,0	-	249,0	249,0	-	202,0	202,0	222,0	-	-	-
11	238,0	271,0	-	224,5	246,5	-	201,0	202,0	217,5	-	-	215,0
12	200,0	244,0	-	200,0	244,0	-	200,0	202,0	213,0	169,0	169,0	206,0
14	155,0	190,0	-	155,0	190,0	-	155,0	174,0	178,0	150,0	150,0	173,0
16	126,0	154,0	-	125,0	154,0	-	125,0	153,0	153,0	124,0	133,0	148,0
18	104,0	129,0	-	104,0	129,0	-	104,0	129,0	128,0	103,0	119,0	126,0
20	89,0	110,0	-	88,5	110,0	-	88,5	110,0	109,0	87,5	107,0	107,0
22	76,5	96,0	-	76,5	95,5	-	76,0	95,0	94,0	75,0	94,5	93,0
24	67,0	84,0	-	66,5	84,0	-	66,0	83,5	82,5	65,5	82,5	81,0
26	59,0	74,5	-	58,5	74,0	-	58,0	74,0	72,5	57,5	73,0	71,5
28	52,5	66,5	-	52,0	66,5	-	51,5	66,0	65,0	50,5	65,0	63,5
30	47,0	60,0	-	46,6	59,5	-	46,2	59,0	58,0	45,3	58,5	56,5
34	38,1	49,5	-	37,7	49,1	-	37,3	48,7	47,5	36,3	47,8	46,2
38	31,3	41,5	-	30,8	41,0	-	30,2	40,5	39,3	29,1	39,6	37,9
42	25,7	35,1	-	25,1	34,6	-	24,6	34,1	32,7	23,4	33,0	31,1
46	21,2	29,9	-	20,6	29,3	-	20,0	28,7	27,2	18,8	27,5	25,6
50	17,6	25,5	-	16,9	24,8	-	16,3	24,2	22,7	15,1	23,0	21,1
54	14,6	21,9	-	13,9	21,2	-	13,2	20,5	19,0	12,0	19,3	17,3
58	12,2	18,9	-	11,3	18,1	-	10,6	17,4	15,8	9,4	16,1	14,2
62	-	-	-	9,2	15,5	-	8,4	14,7	13,2	7,2	13,5	11,5
66	-	-	-	-	-	-	6,6	12,5	10,9	5,3	11,2	9,2
70	-	-	-	-	-	-	5,1	10,6	9,0	-	9,2	7,2
74	-	-	-	-	-	-	-	-	-	-	7,6	5,5
75	-	-	-	-	-	-	-	-	-	-	-	5,2

m	90 m			96 m			102 m			108 m		
	SH/LH		SH/LH SGLmax.	SH/LH		SH/LH SGLmax.	SH/LH		SH/LH SGLmax.	SH/LH		SH/LH SGLmax.
	160 t	180 t+60 tZB		160 t	180 t+60 tZB		160 t	180 t+60 tZB		160 t	180 t+60 tZB	
12	154,0	154,0	199,0	137,0	137,0	159,0	-	-	-	-	-	-
13	154,0	154,0	183,0	137,0	137,0	159,0	-	-	145,0	-	-	131,0
14	154,0	154,0	167,0	137,0	137,0	159,0	108,0	108,0	145,0	-	-	131,0
16	124,0	142,0	143,0	123,0	127,0	139,0	99,0	99,0	135,0	-	-	131,0
18	103,0	127,0	125,0	102,0	118,0	121,0	91,0	91,0	117,0	-	-	114,0
20	87,0	108,0	106,0	86,5	108,0	106,0	84,0	84,0	103,0	-	-	100,0
22	74,5	94,0	91,5	74,0	93,0	91,0	73,5	78,0	90,0	-	-	88,5
24	65,0	82,0	80,0	64,0	81,5	79,5	64,0	72,0	78,5	-	-	77,0
26	57,0	72,5	70,5	56,0	72,0	69,5	56,0	68,0	68,5	-	-	67,0
28	50,0	64,5	62,5	49,8	64,0	61,5	49,3	63,5	60,5	-	-	59,0
30	44,7	57,5	55,5	44,1	57,0	55,0	43,7	56,5	54,0	-	-	52,5
34	35,6	47,2	44,9	34,9	46,6	44,3	34,4	46,1	43,1	-	-	41,3
38	28,4	39,0	36,4	27,6	38,4	35,7	27,1	37,8	34,3	-	-	32,5
42	22,7	32,3	29,6	21,9	31,5	28,8	21,4	30,9	27,4	-	-	25,6
46	18,1	26,8	24,0	17,3	26,0	23,3	16,7	25,4	21,8	-	-	20,0
50	14,3	22,2	19,5	13,5	21,4	18,7	12,9	20,8	17,2	-	-	15,4
54	11,2	18,5	15,7	10,4	17,7	14,9	9,8	17,0	13,4	-	-	11,6
58	8,6	15,3	12,5	7,7	14,5	11,7	7,1	13,8	10,2	-	-	8,3
62	6,3	12,6	9,8	5,4	11,7	8,9	4,8	11,1	7,4	-	-	5,5
64	5,3	11,4	8,6	-	10,5	7,7	-	9,9	6,2	-	-	4,3
66	4,4	10,3	7,5	-	9,4	6,6	-	8,7	5,0	-	-	-
67	-	9,8	6,9	-	8,8	6,0	-	8,1	4,5	-	-	-
70	-	8,3	5,4	-	7,3	4,5	-	6,6	-	-	-	-
71	-	7,8	4,9	-	6,8	4,0	-	6,1	-	-	-	-
73	-	6,9	4,1	-	5,9	-	-	5,2	-	-	-	-
74	-	6,5	-	-	5,5	-	-	4,8	-	-	-	-
78	-	5,0	-	-	4,0	-	-	-	-	-	-	-

**Remarks · Bemerkungen · Remarques**

For SH/LH SGLmax. a boom power-kit is required · Für SH/LH SGLmax. ist ein Ausleger-Verstärkungs-Kit erforderlich ·  
Un kit à fortifier de flèche principale est nécessaire pour SH/LH SGLmax.

**SSL/HSSL, SSL/LSL WORKING RANGES · ARBEITSBEREICHE · PORTÉES**

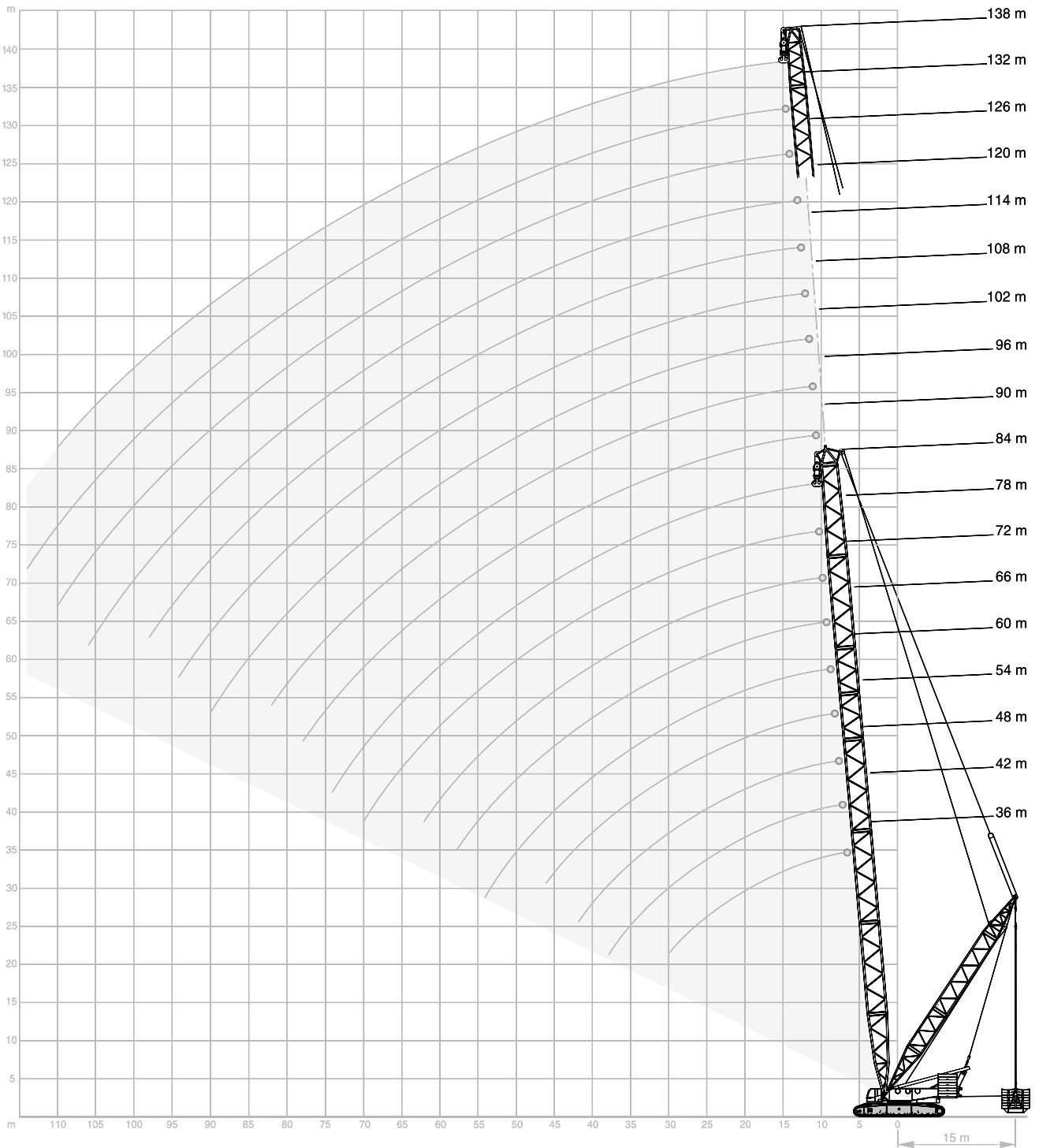



**SSL/HSSL LIFTING CAPACITIES · TRAGFÄHIGKEITEN ·**  
**CAPACITÉS DE LEVAGE**



180 t + 60 t ZB		8,40 m		360°		DIN/ISO	
36 m		42 m		48 m		54 m	
SSL		HSSL		SSL		HSSL	
0 t		0 t-300 t		0 t		0 t-300 t	
11-15m		17m		11-15m		11-15m	
m	t	t	t	t	t	t	t
7	578,0	600,0	600,0	-	-	-	-
8	505,0	600,0	600,0	-	504,0	593,0	593,0
9	427,0	600,0	600,0	-	425,0	593,0	593,0
10	358,0	599,0	599,0	-	356,0	593,0	593,0
12	261,0	583,0	583,0	-	259,0	574,0	574,0
14	204,0	519,0	549,0	-	202,0	516,0	534,0
16	166,0	454,0	482,0	-	165,0	451,0	479,0
18	140,0	403,0	428,0	-	138,0	401,0	426,0
20	120,0	363,0	371,0	-	118,0	360,0	382,0
22	104,0	323,0	323,0	-	102,0	326,0	345,0
24	92,5	284,0	284,0	-	90,5	294,0	305,0
26	82,5	251,0	251,0	-	80,5	269,0	273,0
28	74,5	228,0	222,0	-	72,5	245,0	245,0
30	67,5	203,0	196,0	-	65,5	220,0	220,0
34	-	-	-	-	54,5	180,0	178,0
38	-	-	-	-	46,8	149,0	143,0
42	-	-	-	-	-	-	-
46	-	-	-	-	-	-	-
49	-	-	-	-	-	-	-

60 m		66 m		72 m		78 m	
SSL		HSSL		SSL		HSSL	
0 t		0 t-300 t		0 t		0 t-300 t	
11-15m		17m		11-15m		11-15m	
m	t	t	t	t	t	t	t
9	426,0	476,0	476,0	476,0	-	-	-
10	354,0	476,0	476,0	476,0	353,0	414,0	414,0
11	305,5	476,0	476,0	476,0	304,5	414,0	414,0
12	257,0	476,0	476,0	476,0	256,0	414,0	414,0
14	199,0	476,0	476,0	476,0	198,0	414,0	414,0
16	161,0	446,0	470,0	444,0	160,0	409,0	409,0
18	134,0	395,0	420,0	394,0	133,0	388,0	388,0
20	114,0	354,0	377,0	353,0	113,0	353,0	367,0
22	99,0	321,0	341,0	319,0	98,0	319,0	340,0
24	86,5	292,0	311,0	291,0	85,5	291,0	310,0
26	76,5	265,0	285,0	265,0	75,5	265,0	284,0
28	68,0	243,0	261,0	242,0	67,0	242,0	259,0
30	61,0	224,0	240,0	223,0	60,0	223,0	238,0
34	50,0	191,0	204,0	191,6	48,9	189,0	204,0
38	41,6	165,0	176,0	165,6	40,3	164,0	176,0
42	34,8	146,0	152,0	145,0	33,3	144,0	155,0
46	29,3	130,0	131,0	128,3	27,7	129,0	135,0
50	25,0	113,0	113,0	111,3	23,2	115,0	118,0
54	21,6	97,5	96,5	97,0	19,6	103,0	103,0
58	-	-	-	-	16,7	89,5	89,5
59	-	-	-	-	-	-	84,5
62	-	-	-	-	-	-	-
65	-	-	-	-	-	-	-
66	-	-	-	-	-	-	-
70	-	-	-	-	-	-	-

**Remarks · Bemerkungen · Remarques**

For HSSL a boom power-kit is required  
Für HSSL ist ein Ausleger-Verstärkungs-Kit erforderlich  
Un kit à fortifier de flèche principale est nécessaire pour HSSL

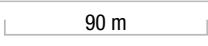
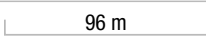
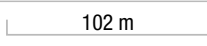
## SSL/HSSL LIFTING CAPACITIES · TRAGFÄHIGKEITEN · CAPACITÉS DE LEVAGE

180 t + 60 t ZB		8,40 m		360°		DIN/ISO			
									
SSL		HSSL		HSSL		HSSL		HSSL	
0 t		0 t-300 t		0 t-300 t		0 t-300 t		0 t-300 t	
11-15m		17m		11-15m		11-15m		11-15m	
m	t	t	t	t	t	t	t	t	t
12	253,0	281,0	281,0	307,0	289,0	254,0	-	-	-
13	224,0	281,0	281,0	307,0	288,5	253,5	218,0	191,0	191,0
14	195,0	281,0	281,0	307,0	288,0	253,0	218,0	191,0	191,0
16	157,0	281,0	281,0	307,0	287,0	250,0	215,0	189,0	189,0
18	130,0	281,0	281,0	307,0	286,0	248,0	212,0	187,0	187,0
20	110,0	278,0	278,0	307,0	285,0	246,0	210,0	184,0	184,0
22	94,5	271,0	271,0	305,0	274,0	242,0	208,0	182,0	182,0
24	82,0	265,0	265,0	284,0	264,0	236,0	203,0	179,0	179,0
26	72,0	259,0	259,0	260,0	254,0	231,0	198,0	174,0	174,0
28	63,5	240,0	241,0	238,0	237,0	226,0	193,0	170,0	170,0
30	56,0	219,0	223,0	218,0	217,0	213,0	188,0	165,0	165,0
34	44,8	186,0	192,0	186,6	186,3	183,6	173,3	155,6	155,6
38	35,6	160,0	168,0	160,3	160,3	158,3	156,0	144,6	144,6
42	28,4	140,0	148,0	139,0	139,0	137,0	136,0	132,0	132,0
46	22,7	124,0	132,0	123,6	123,6	121,6	120,6	118,0	118,0
50	18,0	111,0	119,0	110,3	110,1	108,1	107,3	105,5	105,5
54	14,1	100,0	106,0	99,0	98,5	96,5	96,0	94,5	94,5
58	10,9	91,0	95,5	90,0	89,5	87,3	86,8	85,0	85,0
62	8,2	83,0	85,5	81,9	81,0	79,3	78,8	76,8	76,8
66	5,9	76,0	76,5	74,0	74,0	72,0	71,5	69,5	69,5
70	-	68,0	68,0	65,6	67,0	65,6	65,5	63,5	63,5
74	-	60,0	60,0	57,5	60,0	59,3	59,6	58,0	58,0
75	-	-	-	56,0	58,2	57,7	58,2	56,5	56,5
78	-	-	-	-	53,0	53,0	54,0	52,0	52,0
80	-	-	-	-	50,0	49,5	51,2	49,5	49,5
82	-	-	-	-	-	46,6	48,4	47,0	47,0
85	-	-	-	-	-	43,0	44,2	43,3	43,3
86	-	-	-	-	-	-	42,9	42,1	42,1
90	-	-	-	-	-	-	38,2	37,3	37,3
91	-	-	-	-	-	-	37,5	36,1	36,1
94	-	-	-	-	-	-	-	33,0	33,0
96	-	-	-	-	-	-	-	31,6	31,6
98	-	-	-	-	-	-	-	-	-

### Remarks · Bemerkungen · Remarques

For HSSL a boom power-kit is required  
 Für HSSL ist ein Ausleger-Verstärkungs-Kit erforderlich  
 Un kit à fortifier de flèche principale est nécessaire pour HSSL

**SSL/LSL LIFTING CAPACITIES · TRAGFÄHIGKEITEN ·**  
**CAPACITÉS DE LEVAGE**

180 t + 60 t ZB		11-15 m		8,40 m		360°		DIN/ISO	
m	90 m		96 m			102 m			
	0 t	SSL/LSL	SSL/LSL	SSL/LSL	SSL/LSL	SSL/LSL	SSL/LSL	SSL/LSL	
	t	t	t	t	t	t	t	t	
12	239,0	248,0	250,0	207,0	215,0	225,0	-	-	-
13	220,5	248,0	250,0	204,5	214,5	224,0	-	-	204,0
14	202,0	248,0	250,0	202,0	214,0	223,0	173,0	181,0	203,0
16	163,0	248,0	250,0	163,0	213,0	220,0	163,0	179,0	199,0
18	136,0	248,0	250,0	136,0	212,0	217,0	136,0	178,0	196,0
20	116,0	246,0	249,0	116,0	211,0	215,0	115,0	176,0	193,0
22	100,0	241,0	241,0	100,0	209,0	210,0	99,5	174,0	190,0
24	88,0	235,0	236,0	87,5	205,0	205,0	87,0	172,0	185,0
26	77,5	230,0	230,0	77,0	202,0	200,0	77,0	170,0	180,0
28	69,0	224,0	224,0	68,5	199,0	195,0	68,0	168,0	175,0
30	62,0	212,0	205,0	61,5	194,0	188,0	61,0	166,0	170,0
34	50,5	191,0	176,3	50,0	178,0	170,0	49,6	156,0	157,3
38	41,7	166,0	152,3	41,2	163,0	151,3	40,8	145,0	144,3
42	34,5	146,0	133,0	33,9	145,0	132,0	33,4	134,0	131,0
46	28,7	129,0	118,3	28,0	129,0	117,3	27,5	124,0	116,3
50	23,8	116,0	105,6	23,2	115,0	104,8	22,6	114,0	103,6
54	19,8	105,0	95,0	19,1	104,0	94,5	18,5	104,0	93,0
58	16,4	95,5	86,6	15,7	95,0	86,1	15,1	94,5	84,5
62	13,5	87,5	79,0	12,7	87,0	78,5	12,1	86,5	77,1
66	11,0	80,5	72,5	10,2	80,0	71,5	9,6	79,0	70,5
70	8,8	74,0	66,8	8,0	73,5	66,1	7,4	73,0	64,8
74	6,9	68,5	61,8	6,1	68,0	61,1	5,4	67,5	59,6
78	5,3	61,0	57,5	4,4	63,0	56,5	-	62,5	55,0
80	-	-	55,0	-	59,7	54,5	-	60,2	53,0
82	-	-	-	-	56,5	52,5	-	58,0	50,8
85	-	-	-	-	-	49,9	-	53,8	47,5
86	-	-	-	-	-	-	-	52,5	46,5
90	-	-	-	-	-	-	-	47,2	42,5

108 m		114 m			120 m		
m	SSL/LSL		SSL/LSL	SSL/LSL	SSL/LSL	SSL/LSL	SSL/LSL
	0 t	0 t-300 t	0 t	0 t-300 t	0 t	0 t-300 t	0 t
	t	t	t	t	t	t	t
13	-	-	183,0	-	-	-	-
14	147,0	153,0	183,0	129,0	134,0	162,0	119,0
16	143,0	150,0	181,0	126,0	132,0	161,0	117,0
18	135,0	147,0	180,0	124,0	131,0	160,0	115,0
20	114,0	145,0	179,0	114,0	129,0	159,0	112,0
22	99,0	142,0	179,0	98,5	127,0	158,0	98,5
24	86,0	139,0	177,0	86,0	126,0	157,0	86,0
26	76,0	136,0	174,0	75,5	124,0	155,0	75,5
28	67,5	133,0	170,0	67,0	122,0	154,0	67,0
30	60,0	130,0	166,0	60,0	120,0	152,0	59,5
34	48,7	124,0	153,3	48,4	117,0	146,0	48,3
38	39,7	119,0	142,3	39,3	113,0	138,0	39,1
42	32,4	114,0	129,0	32,0	108,0	128,0	31,7
46	26,4	108,0	114,3	26,0	104,0	113,3	25,8
50	21,5	103,0	101,8	21,1	99,0	100,6	20,8
54	17,4	98,0	91,5	17,0	95,0	90,0	16,7
58	14,0	93,0	82,7	13,5	91,0	81,6	13,2
62	11,0	85,5	75,1	10,5	85,0	74,0	10,3
66	8,4	78,5	68,5	7,9	78,0	67,0	7,7
70	6,2	72,0	62,8	5,7	71,5	61,6	5,4
74	4,2	66,5	57,7	-	66,0	56,4	-
78	-	61,5	53,0	-	61,0	52,0	-
82	-	57,5	49,2	-	57,0	48,0	-
86	-	53,0	45,7	-	53,0	44,2	-
90	-	48,0	42,3	-	48,8	40,6	-
94	-	43,1	39,1	-	44,3	37,5	-
96	-	-	37,6	-	42,1	36,0	-
98	-	-	-	-	40,0	34,6	-
101	-	-	-	-	-	32,5	-
102	-	-	-	-	-	-	-
106	-	-	-	-	-	-	-

## SSL/LSL LIFTING CAPACITIES · TRAGFÄHIGKEITEN · CAPACITÉS DE LEVAGE

180 t + 60 t ZB		11-15 m		8,40 m		360°		DIN/ISO	
m	126 m			132 m			138 m		
	0 t	SSL/LSL	SSL/LSL SGLmax.	0 t	SSL/LSL	SSL/LSL SGLmax.	0 t	SSL/LSL	SSL/LSL SGLmax.
15	-	-	129,0	-	-	117,0	-	-	-
16	106,0	109,0	129,0	92,0	96,0	117,0	79,0	82,0	103,0
18	104,0	108,0	128,0	90,0	95,0	116,0	77,0	80,0	102,0
20	103,0	108,0	127,0	88,0	94,0	115,0	74,0	79,0	101,0
22	98,5	107,0	126,0	87,0	93,0	114,0	72,0	78,0	100,0
24	85,5	106,0	125,0	84,5	92,0	113,0	70,0	77,0	99,0
26	75,5	105,0	124,0	74,5	91,0	112,0	69,0	75,0	98,0
28	66,5	104,0	124,0	65,5	90,0	111,0	65,0	74,0	97,0
30	59,5	103,0	123,0	58,5	89,0	110,0	58,0	73,0	95,5
34	48,0	101,0	121,0	47,0	87,0	108,0	46,3	71,0	93,5
38	38,8	99,0	117,3	37,6	86,0	105,4	36,8	68,0	91,5
42	31,4	97,0	112,0	30,2	85,0	102,0	29,4	66,0	89,0
46	25,4	94,0	105,3	24,2	83,0	97,0	23,4	63,0	85,3
50	20,4	91,0	97,5	19,3	82,0	91,3	18,5	61,0	81,6
54	16,3	88,0	87,5	15,2	80,0	86,0	14,3	58,0	78,0
58	12,8	85,0	79,1	11,7	78,0	77,6	10,8	55,0	74,0
62	9,8	82,0	71,5	8,6	75,0	69,9	7,8	52,0	68,0
66	7,2	77,0	64,5	6,0	73,0	63,0	5,2	49,0	61,5
70	4,9	71,0	58,8	-	69,5	57,3	-	46,0	55,5
74	-	65,5	53,7	-	64,5	52,0	-	42,0	50,1
78	-	60,5	49,1	-	59,5	47,2	-	39,0	45,4
82	-	56,0	44,8	-	55,0	42,8	-	36,0	41,1
86	-	52,0	40,8	-	51,0	39,0	-	33,9	37,2
90	-	48,7	37,3	-	47,5	35,4	-	32,9	33,6
94	-	45,0	34,1	-	43,7	32,2	-	31,9	30,4
98	-	41,3	31,2	-	40,2	29,3	-	30,9	27,5
102	-	37,7	28,6	-	36,9	26,7	-	29,8	24,8
106	-	34,2	26,2	-	33,6	24,3	-	28,8	22,4
110	-	30,7	23,5	-	30,4	21,9	-	27,8	20,1
111	-	-	22,8	-	29,6	21,3	-	27,5	19,6
114	-	-	-	-	27,3	19,6	-	26,8	18,1
116	-	-	-	-	-	18,0	-	25,6	16,9
118	-	-	-	-	-	-	-	24,4	15,5
122	-	-	-	-	-	-	-	22,0	12,7
126	-	-	-	-	-	-	-	-	-

### Remarks · Bemerkungen · Remarques

For SSL/LSL SGLmax. a boom power-kit is required  
 Für SSL/LSL SGLmax. ist ein Ausleger-Verstärkungs-Kit erforderlich  
 Un kit à fortifier de flèche principale est nécessaire pour SSL/LSL SGLmax.

**SH+LF2, SH/LH+LF2 WORKING RANGES · ARBEITSBEREICHE ·**  
**PORTÉES**

10°

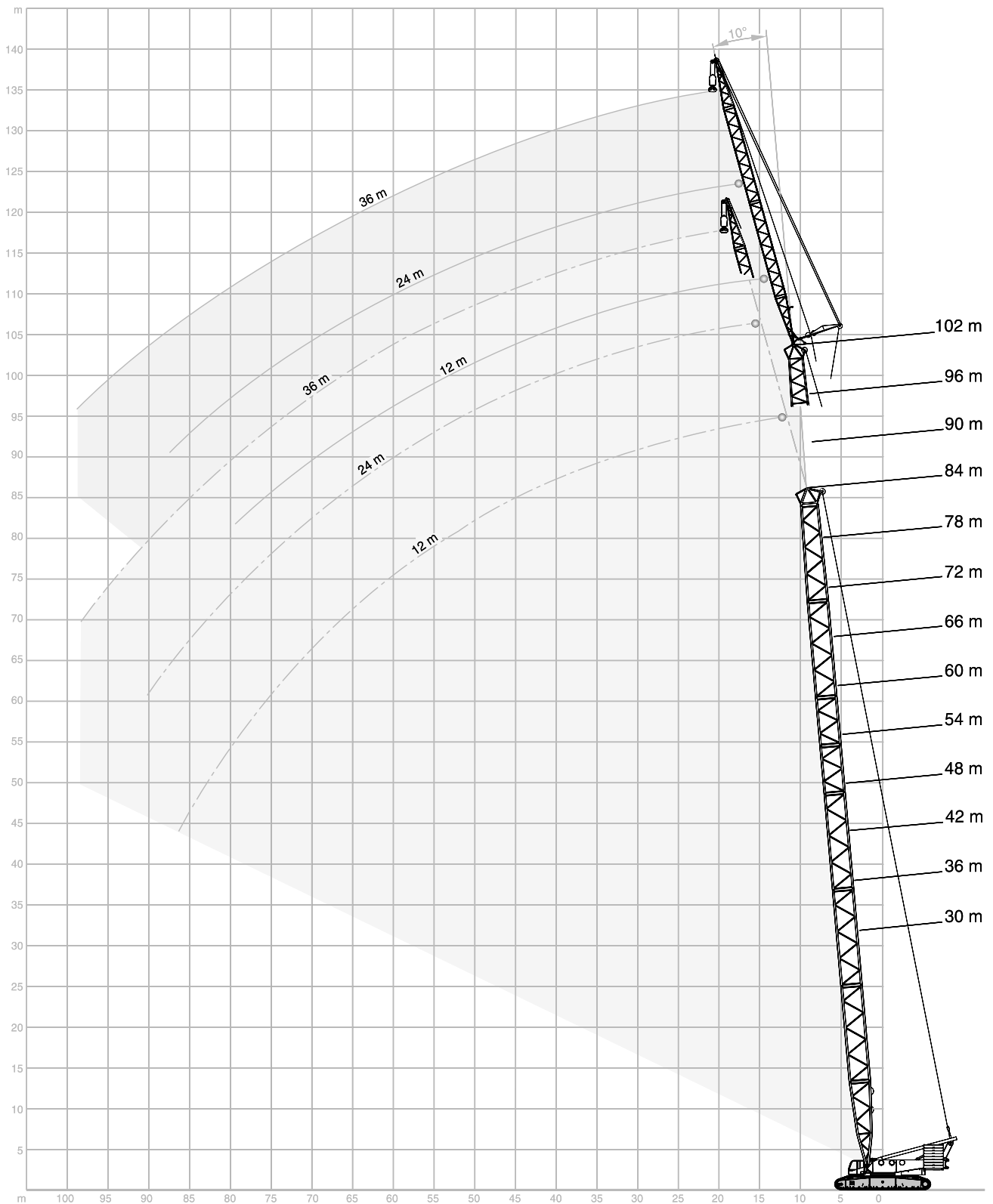

## SH+LF2 LIFTING CAPACITIES · TRAGFÄHIGKEITEN · CAPACITÉS DE LEVAGE

		180 t + 60 t ZB			12 m			8,40 m			360°			DIN/ISO		
		30 m			36 m			42 m			48 m			54 m		
		10°	15°	20°	10°	15°	20°	10°	15°	20°	10°	15°	20°	10°	15°	20°
m	t	t	t	t	t	t	t	t	t	t	t	t	t	t	t	t
9	125,0	-	-	125,0	-	-	-	-	-	-	-	-	-	-	-	-
10	125,0	107,0	-	125,0	108,0	-	125,0	-	-	125,0	-	-	-	-	-	-
11	124,0	101,0	81,0	125,0	105,0	83,5	125,0	109,0	-	125,0	109,0	-	125,0	-	-	-
12	119,0	94,5	77,0	123,0	99,5	79,5	125,0	103,0	81,5	125,0	106,0	82,0	125,0	109,0	-	-
13	111,0	89,5	73,0	120,0	94,0	76,0	123,0	98,5	78,5	124,0	102,0	80,5	125,0	105,0	82,0	-
14	104,0	84,5	70,0	113,0	89,5	73,0	120,0	93,5	75,5	122,0	97,5	77,5	124,0	100,0	79,0	-
16	93,0	76,5	64,0	100,0	81,5	67,0	108,0	86,0	70,0	114,0	89,5	72,0	119,0	93,0	74,0	-
18	83,5	70,0	59,0	91,0	74,5	62,5	98,0	79,0	65,0	104,0	83,0	67,5	110,0	86,5	70,0	-
20	75,5	64,0	55,0	83,0	69,0	58,5	89,5	73,5	61,0	95,5	77,0	63,5	101,0	80,5	66,0	-
22	68,5	59,5	51,5	76,0	64,0	54,5	82,5	68,5	57,5	88,5	72,5	60,0	94,0	76,0	62,5	-
24	64,0	55,5	48,5	69,5	60,0	51,5	76,5	64,0	54,5	82,5	68,0	57,0	87,5	71,5	59,5	-
26	59,5	52,0	45,8	65,0	56,5	49,0	70,5	60,5	51,5	76,5	64,0	54,5	78,5	67,5	56,5	-
28	55,5	49,2	43,5	61,5	53,0	46,6	66,0	57,0	49,4	71,5	61,0	52,0	70,5	64,0	54,0	-
30	52,5	46,5	41,4	58,0	50,5	44,4	63,0	54,0	47,2	64,5	57,5	49,7	63,5	61,0	52,0	-
34	46,9	42,2	38,1	51,5	45,9	40,8	55,5	49,5	43,4	54,0	52,5	45,8	53,0	53,0	48,0	-
38	42,6	38,9	35,6	47,1	42,2	38,0	47,3	45,5	40,4	45,8	46,1	42,6	44,7	45,0	44,7	-
39	41,8	38,3	-	45,9	41,4	37,4	45,6	44,3	39,7	44,1	44,4	41,9	43,0	43,3	43,2	-
40	-	37,7	-	44,7	40,7	36,9	44,0	43,2	39,1	42,5	42,8	41,2	41,4	41,7	41,7	-
42	-	-	-	42,3	39,3	35,8	40,8	41,0	37,9	39,3	39,6	39,8	38,1	38,4	38,7	-
43	-	-	-	40,9	38,7	35,4	39,5	39,7	37,4	38,0	38,2	38,4	36,8	37,0	37,3	-
45	-	-	-	38,3	37,7	-	36,9	37,1	36,4	35,4	35,6	35,8	34,2	34,4	34,6	-
46	-	-	-	-	-	-	35,6	35,8	35,9	34,1	34,3	34,5	32,9	33,1	33,3	-
48	-	-	-	-	-	-	33,5	33,6	33,6	31,9	32,1	32,3	30,7	30,9	31,1	-
50	-	-	-	-	-	-	31,4	31,5	-	29,8	30,0	30,1	28,6	28,8	28,9	-
53	-	-	-	-	-	-	-	-	-	27,1	27,2	27,3	25,7	25,9	26,1	-
54	-	-	-	-	-	-	-	-	-	26,2	26,3	-	24,8	25,0	25,2	-
55	-	-	-	-	-	-	-	-	-	25,4	25,5	-	24,0	24,2	24,3	-
58	-	-	-	-	-	-	-	-	-	-	-	-	21,6	21,8	21,9	-
60	-	-	-	-	-	-	-	-	-	-	-	-	20,2	20,3	-	-
61	-	-	-	-	-	-	-	-	-	-	-	-	-	19,6	-	-
62	-	-	-	-	-	-	-	-	-	-	-	-	-	-	-	-

**SH+LF2 LIFTING CAPACITIES · TRAGFÄHIGKEITEN ·**  
**CAPACITÉS DE LEVAGE**

		180 t + 60 t ZB			12 m			8,40 m			360°			DIN/ISO		
		60 m			66 m			72 m			78 m			84 m		
		10°	15°	20°	10°	15°	20°	10°	15°	20°	10°	15°	20°	10°	15°	20°
m	t	t	t	t	t	t	t	t	t	t	t	t	t	t	t	t
11	125,0	-	-	-	-	-	-	-	-	-	-	-	-	-	-	-
12	125,0	108,0	-	-	125,0	-	-	125,0	-	-	-	-	-	-	-	-
13	125,0	107,0	81,5	-	125,0	106,0	-	125,0	108,0	-	125,0	-	-	125,0	-	-
14	125,0	103,0	80,5	-	125,0	106,0	80,5	125,0	108,0	81,5	125,0	106,0	-	125,0	104,0	-
15	124,0	99,5	78,0	-	125,0	102,0	79,5	125,0	104,0	81,0	125,0	106,0	80,0	123,0	104,0	79,0
16	121,0	96,0	76,0	-	124,0	98,5	77,5	125,0	101,0	78,5	120,0	103,0	80,0	115,0	104,0	79,0
18	115,0	89,5	71,5	-	115,0	92,5	73,5	110,0	95,0	74,5	106,0	97,0	76,0	102,0	99,0	77,0
20	106,0	84,0	68,0	-	103,0	86,5	69,5	98,5	89,5	71,0	95,0	91,5	72,5	91,0	92,0	74,0
22	96,0	79,0	64,5	-	92,5	82,0	66,0	88,5	84,5	68,0	85,0	86,0	69,5	81,5	82,5	70,5
24	87,0	74,5	61,5	-	83,5	77,5	63,0	80,0	80,0	65,0	77,0	78,0	66,5	73,5	74,5	68,0
26	77,0	70,5	58,5	-	76,0	73,5	60,5	72,5	73,5	62,0	70,0	70,5	64,0	66,5	67,5	65,0
28	69,0	67,0	56,0	-	68,0	69,0	58,0	66,5	67,0	59,5	63,5	64,5	61,5	60,5	61,5	62,5
30	62,5	63,0	54,0	-	61,5	62,0	55,5	60,0	60,5	57,5	58,0	59,0	59,0	55,0	56,0	57,0
34	51,5	52,0	50,0	-	50,5	51,0	51,5	49,2	49,7	50,0	48,1	48,7	49,2	46,5	47,2	47,9
38	43,2	43,6	44,0	-	42,2	42,6	43,0	40,8	41,3	41,7	39,7	40,2	40,7	38,3	38,9	39,4
42	36,7	37,0	37,3	-	35,6	36,0	36,3	34,2	34,6	35,0	32,9	33,4	33,9	31,2	31,8	32,3
46	31,4	31,7	32,0	-	30,2	30,6	30,9	28,5	29,0	29,3	27,2	27,7	28,1	25,5	26,0	26,5
50	26,9	27,2	27,4	-	25,6	25,9	26,2	23,9	24,2	24,6	22,5	22,9	23,3	20,8	21,3	21,7
54	23,1	23,3	23,5	-	21,7	22,0	22,2	20,0	20,3	20,6	18,6	19,0	19,3	16,9	17,3	17,7
58	19,8	20,0	20,2	-	18,5	18,7	18,9	16,7	17,0	17,2	15,3	15,6	15,9	13,6	13,9	14,3
62	17,0	17,2	17,3	-	15,7	15,9	16,0	13,9	14,1	14,3	12,5	12,8	13,0	10,7	11,0	11,3
63	16,4	16,6	16,7	-	15,1	15,2	15,3	13,2	13,4	13,6	11,8	12,1	12,3	10,1	10,4	10,6
65	15,2	15,4	-	-	13,9	14,0	14,1	12,0	12,2	12,4	10,6	10,9	11,1	8,9	9,1	9,4
66	-	14,8	-	-	13,3	13,4	13,5	11,4	11,6	11,8	10,0	10,3	10,5	8,3	8,5	8,8
68	-	-	-	-	12,2	12,3	12,4	10,3	10,5	10,7	8,9	9,1	9,4	7,2	7,4	7,7
70	-	-	-	-	11,2	11,3	-	9,3	9,5	9,6	7,9	8,1	8,3	6,1	6,4	6,6
71	-	-	-	-	10,7	10,8	-	8,8	9,0	9,1	7,4	7,6	7,8	5,6	5,9	6,1
73	-	-	-	-	-	-	-	7,9	8,0	8,2	6,5	6,6	6,8	4,7	4,9	5,1
74	-	-	-	-	-	-	-	7,5	7,6	-	6,1	6,2	6,4	4,3	4,5	4,6
75	-	-	-	-	-	-	-	7,1	7,2	-	5,6	5,8	5,9	3,8	4,0	4,2
76	-	-	-	-	-	-	-	6,7	6,8	-	5,2	5,4	5,5	-	3,6	3,8
78	-	-	-	-	-	-	-	-	-	-	4,4	4,6	4,7	-	-	-
80	-	-	-	-	-	-	-	-	-	-	3,7	3,8	-	-	-	-



## SH/LH+LF2 LIFTING CAPACITIES · TRAGFÄHIGKEITEN · CAPACITÉS DE LEVAGE

		180 t + 60 t ZB			12 m			8,40 m			360°			DIN/ISO		
m	66 m			72 m			78 m									
	SH/LH+LF2			SH/LH+LF2			SH/LH+LF2	SH/LH+LF2	SH/LH+LF2	SH/LH+LF2	SH/LH+LF2	SH/LH+LF2	SH/LH+LF2			
	10°	15°	20°	10°	15°	20°	LF2	SGLmax.	LF2	SGLmax.	LF2	SGLmax.	LF2	SGLmax.		
t	t	t	t	t	t	t	t	t	t	t	t	t	t			
12	125,0	-	-	124,0	-	-	-	-	-	-	-	-	-	-		
13	125,0	111,0	-	124,0	107,0	-	116,0	125,0	-	-	-	-	-	-		
14	125,0	107,0	83,0	124,0	107,0	83,0	116,0	125,0	101,0	117,0	-	-	-	-		
15	125,0	103,0	80,5	124,0	105,0	81,5	114,0	125,0	101,0	115,0	81,0	88,5	-	-		
16	125,0	99,5	78,0	123,0	102,0	79,5	112,0	125,0	100,0	113,0	80,5	88,5	-	-		
18	116,0	93,5	74,0	112,0	96,0	75,5	109,0	124,0	97,5	107,0	76,5	84,5	-	-		
20	104,0	87,5	70,0	100,0	90,5	72,0	97,5	112,0	92,5	97,5	73,0	80,5	-	-		
22	94,0	82,5	67,0	91,0	85,5	68,5	88,0	97,0	88,0	87,5	70,0	77,0	-	-		
24	85,0	78,5	64,0	82,0	81,0	65,5	79,5	85,0	80,5	79,5	67,0	74,0	-	-		
26	77,5	74,5	61,0	75,0	75,5	63,0	72,5	75,0	73,5	72,0	64,5	71,0	-	-		
28	69,0	70,0	58,5	68,5	69,0	60,5	66,5	67,0	67,0	66,0	62,0	66,5	-	-		
30	62,5	63,0	56,0	61,5	62,0	58,0	61,0	60,0	61,5	60,5	59,5	61,0	-	-		
34	51,5	52,0	52,0	50,5	51,0	51,5	50,0	49,3	50,5	49,8	51,0	50,0	-	-		
38	43,2	43,6	44,0	42,5	42,9	43,3	41,8	40,8	42,3	41,3	42,7	41,8	-	-		
42	36,6	37,0	37,3	35,9	36,2	36,6	35,2	34,2	35,6	34,6	36,0	35,0	-	-		
46	31,3	31,6	31,9	30,5	30,9	31,2	29,7	28,5	30,1	28,9	30,5	29,3	-	-		
50	26,8	27,1	27,4	25,9	26,2	26,5	25,1	23,8	25,4	24,2	25,7	24,5	-	-		
54	22,9	23,2	23,4	22,0	22,2	22,5	21,2	19,9	21,5	20,2	21,7	20,5	-	-		
58	19,6	19,9	20,1	18,7	18,9	19,1	17,9	16,6	18,1	16,9	18,4	17,1	-	-		
62	16,9	17,0	17,2	15,9	16,1	16,3	15,0	13,7	15,3	14,0	15,5	14,2	-	-		
66	14,4	14,6	14,7	13,4	13,6	13,8	12,6	11,3	12,8	11,5	13,0	11,7	-	-		
68	13,4	13,5	13,6	12,3	12,5	12,7	11,5	10,2	11,7	10,4	11,9	10,6	-	-		
70	12,4	12,5	-	11,3	11,5	11,6	10,5	9,1	10,6	9,3	10,8	9,5	-	-		
71	11,9	12,0	-	10,8	11,0	11,1	10,0	8,6	10,1	8,8	10,3	9,0	-	-		
73	-	-	-	9,9	10,0	10,2	9,1	7,7	9,2	7,8	9,3	8,0	-	-		
74	-	-	-	9,5	9,6	-	8,6	7,3	8,8	7,4	8,9	7,6	-	-		
76	-	-	-	8,7	8,8	-	7,8	6,4	7,9	6,6	8,0	6,7	-	-		
77	-	-	-	-	8,4	-	7,4	6,0	7,5	6,2	7,6	6,3	-	-		
78	-	-	-	-	-	-	7,0	5,6	7,1	5,8	7,2	5,9	-	-		
81	-	-	-	-	-	-	5,9	4,6	6,0	4,6	-	-	-	-		
82	-	-	-	-	-	-	-	-	5,7	4,3	-	-	-	-		

### Remarks · Bemerkungen · Remarques

For SH/LH+LF2 SGLmax. a boom power-kit is required  
 Für SH/LH+LF2 SGLmax. ist ein Ausleger-Verstärkungs-Kit erforderlich  
 Un kit à fortifier de flèche principale est nécessaire pour SH/LH+LF2 SGLmax.



**SH/LH+LF2 LIFTING CAPACITIES · TRAGFÄHIGKEITEN ·**  
**CAPACITÉS DE LEVAGE**

180 t + 60 t ZB 12 m 8,40 m 360° DIN/ISO

m	84 m						90 m					
	SH/LH+LF2		SH/LH+LF2 SGLmax.		SH/LH+LF2		SH/LH+LF2 SGLmax.		SH/LH+LF2		SH/LH+LF2 SGLmax.	
	10°		15°		20°		10°		15°		20°	
t	t	t	t	t	t	t	t	t	t	t	t	t
14	106,0	125,0	-	-	-	-	88,5	125,0	-	-	-	-
15	106,0	125,0	95,5	112,0	83,5	-	88,5	125,0	81,0	111,0	-	-
16	105,0	125,0	95,5	112,0	81,5	86,0	88,5	125,0	81,0	111,0	75,0	85,5
18	103,0	125,0	93,5	105,0	78,0	84,5	86,5	119,0	80,0	100,0	74,5	85,5
20	94,0	111,0	92,0	94,0	74,5	81,0	84,0	107,0	78,0	90,0	72,5	82,0
22	85,0	96,0	86,0	84,5	71,5	77,5	81,5	95,0	76,0	81,0	71,0	79,0
24	77,0	84,0	78,0	76,5	68,5	74,5	74,5	82,5	74,5	73,0	69,5	74,0
26	70,0	74,0	71,0	69,5	65,5	70,0	67,5	73,0	68,5	66,0	67,0	67,0
28	64,0	66,0	65,0	63,0	63,5	64,0	62,0	64,5	62,5	60,5	63,5	61,0
30	59,0	59,0	59,5	58,0	60,0	58,5	56,5	57,5	57,5	55,0	58,0	56,0
34	49,3	48,1	49,9	48,7	50,0	49,3	48,2	46,8	48,8	46,4	49,4	47,1
38	40,9	39,6	41,4	40,2	41,9	40,7	40,1	38,2	40,6	38,9	41,1	39,4
42	34,3	32,8	34,7	33,3	35,1	33,8	33,4	31,1	33,9	31,7	34,4	32,3
46	28,6	27,0	29,1	27,5	29,5	28,0	27,7	25,4	28,1	25,9	28,6	26,4
50	24,0	22,3	24,3	22,8	24,7	23,1	23,0	20,7	23,4	21,1	23,8	21,6
54	20,1	18,4	20,4	18,8	20,7	19,1	19,1	16,7	19,4	17,1	19,8	17,5
58	16,7	15,1	17,0	15,4	17,3	15,7	15,7	13,4	16,1	13,7	16,4	14,1
62	13,9	12,2	14,2	12,5	14,4	12,8	12,9	10,5	13,2	10,8	13,4	11,1
66	11,4	9,8	11,7	10,0	11,9	10,2	10,4	8,0	10,7	8,3	10,9	8,6
70	9,3	7,6	9,5	7,8	9,7	8,0	8,3	5,9	8,5	6,1	8,7	6,3
74	7,4	5,7	7,6	5,9	7,8	6,1	6,4	4,0	6,6	4,2	6,8	4,4
75	7,0	5,3	7,1	5,4	7,3	5,6	5,9	3,5	6,1	3,7	6,3	3,9
78	5,8	4,1	5,9	4,2	6,1	4,4	4,7	-	4,9	-	5,1	-
79	5,4	3,7	5,5	3,8	5,7	4,0	4,3	-	4,5	-	4,7	-
80	5,0	-	5,2	-	5,3	3,6	3,9	-	4,1	-	4,3	-
81	4,6	-	4,8	-	4,9	-	3,6	-	3,8	-	3,9	-
82	4,3	-	4,5	-	4,6	-	-	-	-	-	3,5	-
83	4,0	-	4,1	-	4,2	-	-	-	-	-	-	-
84	3,7	-	3,8	-	-	-	-	-	-	-	-	-

m	96 m						102 m					
	SH/LH+LF2		SH/LH+LF2 SGLmax.		SH/LH+LF2		SH/LH+LF2 SGLmax.		SH/LH+LF2		SH/LH+LF2 SGLmax.	
	10°		15°		20°		10°		15°		20°	
t	t	t	t	t	t	t	t	t	t	t	t	t
15	84,5	110,0	-	-	-	-	70,5	103,0	-	-	-	-
16	84,5	110,0	77,5	103,0	-	-	70,5	103,0	65,0	98,0	-	-
17	83,0	109,0	77,5	100,0	71,5	83,0	70,5	103,0	65,0	95,5	60,5	83,5
18	82,0	108,0	77,0	97,0	71,5	83,0	69,5	103,0	65,0	93,0	60,5	83,5
20	80,0	104,0	75,0	87,0	70,5	81,5	67,5	99,5	63,5	83,0	60,0	82,0
22	78,0	93,5	73,5	78,0	69,0	78,5	65,5	90,0	62,0	74,5	58,5	75,5
24	71,5	82,0	72,0	70,5	67,5	71,5	64,0	80,5	60,5	67,0	57,0	68,5
26	65,0	72,0	66,0	64,0	66,0	64,5	62,5	71,0	59,0	61,0	55,5	62,0
28	59,5	64,0	60,5	58,0	61,0	59,0	57,5	62,5	57,5	55,0	54,5	56,0
30	54,5	57,0	55,5	53,0	56,0	53,5	52,5	55,5	53,5	50,0	53,5	51,0
34	46,3	45,9	46,9	44,5	47,5	45,2	44,5	44,6	45,2	42,0	45,8	42,7
38	39,3	37,2	39,8	37,5	40,3	38,1	37,8	35,7	38,4	35,1	38,9	35,7
42	32,4	30,1	32,9	30,7	33,4	31,3	31,5	28,5	32,1	29,2	32,6	29,8
46	26,7	24,4	27,1	24,9	27,6	25,4	25,8	22,7	26,3	23,3	26,8	23,9
50	22,0	19,6	22,4	20,1	22,8	20,6	21,1	18,0	21,5	18,5	21,9	19,0
54	18,0	15,7	18,4	16,1	18,8	16,5	17,1	14,0	17,5	14,5	17,9	14,9
58	14,7	12,3	15,0	12,7	15,3	13,0	13,8	10,6	14,1	11,1	14,5	11,4
62	11,8	9,4	12,1	9,8	12,4	10,1	10,9	7,7	11,2	8,1	11,5	8,5
66	9,3	6,9	9,6	7,2	9,9	7,5	8,4	5,2	8,7	5,6	9,0	5,9
67	8,7	6,4	9,0	6,6	9,3	6,9	-	4,6	-	5,0	8,4	5,3
69	7,7	5,3	7,9	5,5	8,2	5,8	-	3,6	-	3,9	-	4,1
70	7,2	4,8	7,4	5,0	7,7	5,3	-	-	-	-	-	3,6
72	6,2	3,8	6,4	4,0	6,7	4,3	-	-	-	-	-	-
73	5,7	-	6,0	3,6	6,2	3,8	-	-	-	-	-	-
74	5,3	-	5,5	-	5,7	-	-	-	-	-	-	-
78	3,6	-	3,8	-	4,0	-	-	-	-	-	-	-
79	-	-	-	-	3,6	-	-	-	-	-	-	-

Remarks · Bemerkungen · Remarques: see page 24 · siehe Seite 24 · voir page 24

**SSL+LF2, SSL/LSL+LF2 WORKING RANGES · ARBEITSBEREICHE · PORTÉES** **10°**

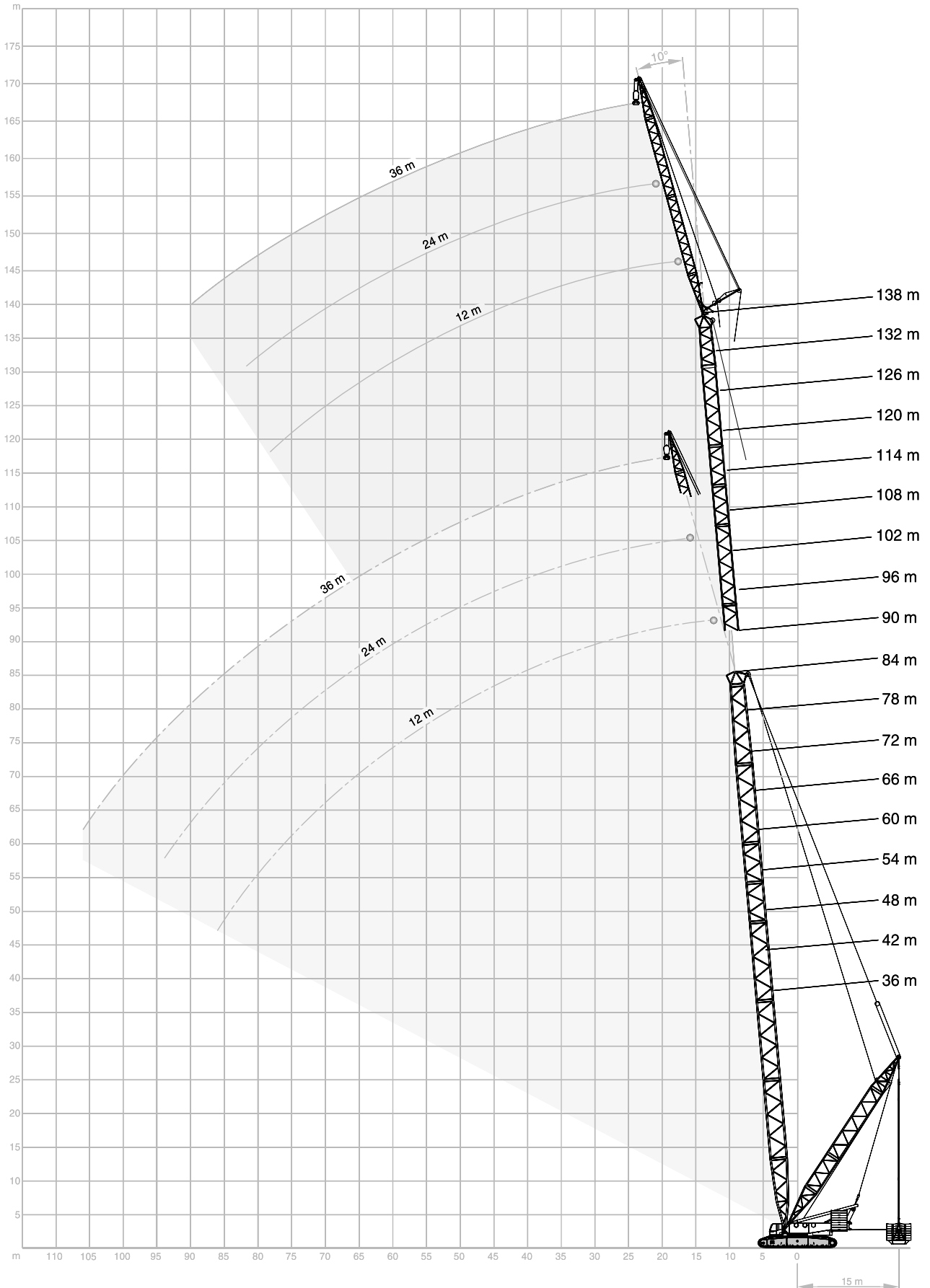

**SSL+LF2 LIFTING CAPACITIES · TRAGFÄHIGKEITEN · CAPACITÉS DE LEVAGE**

180 t + 60 t ZB 11-15 m 0-300 t 12 m 8,40 m 360° DIN/ISO

m	42 m			48 m			54 m						
	SSL			SSL			SSL	HSSL	SSL	HSSL	SSL	HSSL	
	10°	15°	20°	10°	15°	20°	10°		15°		20°		
t	t	t	t	t	t	t	t	t	t	t	t	t	
10	125,0	-	-	-	-	-	-	-	-	-	-	-	-
11	125,0	109,0	-	125,0	-	-	125,0	125,0	-	-	-	-	-
12	125,0	103,0	81,5	125,0	106,0	-	125,0	125,0	109,0	109,0	-	-	-
13	125,0	98,0	78,5	125,0	102,0	80,5	125,0	125,0	105,0	104,5	82,0	82,0	-
14	120,0	93,5	75,5	125,0	97,5	77,5	125,0	125,0	100,0	100,0	79,0	79,0	-
16	108,0	85,5	70,0	114,0	89,5	72,0	120,0	121,0	93,0	93,0	74,0	74,0	-
18	98,0	79,0	65,0	104,0	83,0	67,5	110,0	110,0	86,5	86,5	70,0	70,0	-
20	89,5	73,5	61,0	95,5	77,0	63,5	101,0	102,0	80,5	80,5	66,0	66,0	-
22	82,5	68,5	57,5	88,5	72,5	60,0	94,0	94,5	76,0	76,0	62,5	62,5	-
24	76,5	64,0	54,5	82,5	68,0	57,0	87,5	88,0	71,5	71,5	59,5	59,5	-
26	71,5	60,5	51,5	77,0	64,0	54,0	82,0	82,0	67,5	67,5	56,5	56,5	-
28	67,0	57,0	49,4	72,0	60,5	51,5	77,0	77,5	64,0	64,0	54,0	54,0	-
30	63,0	54,0	47,2	68,0	57,5	49,7	72,5	73,0	61,0	61,0	52,0	52,0	-
34	56,5	49,5	43,4	61,0	52,5	45,8	65,5	66,0	55,5	56,0	48,0	48,2	-
38	51,0	45,5	40,4	55,5	48,5	42,6	59,5	59,8	51,0	51,6	44,7	44,8	-
42	47,2	42,2	37,9	51,0	45,0	40,0	54,5	54,5	47,8	47,8	42,0	42,0	-
46	43,7	39,6	36,0	47,2	42,2	37,8	50,5	50,8	44,7	44,8	39,6	39,7	-
50	41,0	37,6	34,6	44,1	39,8	36,1	47,2	47,4	42,1	42,2	37,7	37,7	-
54	-	-	-	41,5	37,9	34,7	44,4	44,4	40,0	40,0	36,1	36,1	-
55	-	-	-	41,0	37,5	34,5	43,8	43,8	39,5	39,5	35,8	35,8	-
56	-	-	-	-	-	34,3	43,2	43,2	39,1	39,1	35,5	35,5	-
58	-	-	-	-	-	-	42,0	42,1	38,2	38,3	34,9	34,9	-
60	-	-	-	-	-	-	40,9	41,0	37,5	37,5	34,4	-	-
61	-	-	-	-	-	-	-	-	37,2	37,2	34,2	-	-
62	-	-	-	-	-	-	-	-	-	-	-	-	-

m	60 m						66 m						
	SSL	HSSL	SSL	HSSL	SSL	HSSL	SSL	HSSL	SSL	HSSL	SSL	HSSL	
	10°		15°		20°		10°		15°		20°		
t	t	t	t	t	t	t	t	t	t	t	t	t	
11	125,0	125,0	-	-	-	-	-	-	-	-	-	-	-
12	125,0	125,0	107,0	112,0	-	-	125,0	125,0	110,0	-	-	-	-
13	125,0	125,0	107,0	107,5	80,5	83,5	125,0	125,0	110,0	110,0	-	-	-
14	125,0	125,0	103,0	103,0	80,5	80,5	125,0	125,0	106,0	106,0	82,0	82,0	-
16	125,0	125,0	96,0	96,0	76,0	76,0	125,0	125,0	98,5	98,5	77,5	77,5	-
18	115,0	116,0	89,5	89,5	71,5	71,5	120,0	121,0	92,0	92,0	73,5	73,5	-
20	106,0	107,0	84,0	84,0	68,0	68,0	111,0	112,0	86,5	86,5	69,5	69,5	-
22	99,0	99,5	79,0	79,0	64,5	64,5	104,0	104,0	82,0	82,0	66,0	66,0	-
24	92,5	93,0	74,5	74,5	61,5	61,5	97,0	97,5	77,5	77,5	63,0	63,0	-
26	86,5	87,0	70,5	70,5	58,5	58,5	91,5	91,5	73,5	73,5	60,5	60,5	-
28	81,5	82,0	67,0	67,0	56,0	56,0	86,0	86,5	70,0	70,0	58,0	58,0	-
30	77,0	77,5	64,0	64,0	54,0	54,0	81,5	81,5	67,0	67,0	55,5	55,5	-
34	69,5	70,1	58,5	58,6	50,0	50,2	73,5	74,1	61,0	61,6	51,5	51,8	-
38	63,5	63,8	54,0	54,0	46,7	46,8	67,0	67,6	56,5	56,8	48,5	48,5	-
42	58,0	58,5	50,0	50,0	43,8	43,8	61,5	62,0	52,5	52,5	45,6	45,6	-
46	54,0	54,1	47,1	47,1	41,4	41,4	57,0	57,3	49,5	49,5	43,1	43,2	-
50	50,0	50,4	44,4	44,4	39,3	39,4	53,0	53,3	46,6	46,7	40,9	41,0	-
54	47,2	47,3	42,0	42,0	37,6	37,6	50,0	50,0	44,1	44,1	39,1	39,1	-
58	44,6	44,7	40,1	40,1	36,1	36,2	47,2	47,3	42,0	42,0	37,5	37,5	-
62	42,3	42,5	38,4	38,5	35,0	34,9	44,7	44,9	40,1	40,2	36,1	36,2	-
63	41,8	42,0	38,0	38,1	34,7	34,7	44,1	44,3	39,7	39,8	35,8	35,9	-
65	40,9	41,0	37,4	37,4	34,3	-	43,1	43,2	38,9	39,0	35,2	35,3	-
66	-	-	37,1	37,1	34,1	-	42,6	42,7	38,6	38,6	35,0	35,0	-
68	-	-	-	-	-	-	41,7	41,8	37,9	38,0	34,6	34,6	-
70	-	-	-	-	-	-	40,8	40,9	37,3	37,4	34,2	-	-
71	-	-	-	-	-	-	40,4	40,5	37,1	37,1	34,1	-	-
72	-	-	-	-	-	-	-	-	-	-	-	-	-

**Remarks · Bemerkungen · Remarques**

see page 28 · siehe Seite 28 · voir page 28

## SSL+LF2 LIFTING CAPACITIES · TRAGFÄHIGKEITEN · CAPACITÉS DE LEVAGE

180 t + 60 t ZB 11-15 m 0-300 t 12 m 8,40 m 360° DIN/ISO

m	72 m						78 m					
	SSL		HSSL		SSL		HSSL		SSL		HSSL	
	10°	15°	15°	20°	20°	20°	10°	15°	15°	20°	20°	
t	t	t	t	t	t	t	t	t	t	t	t	
12	125,0	125,0	-	-	-	-	-	-	-	-	-	-
13	125,0	125,0	108,0	112,0	-	-	125,0	125,0	-	-	-	-
14	125,0	125,0	108,0	108,0	81,0	83,0	125,0	125,0	106,0	110,0	-	-
15	125,0	125,0	104,0	104,5	81,0	80,7	125,0	125,0	106,0	106,5	80,0	82,0
16	125,0	125,0	101,0	101,0	78,5	78,5	125,0	125,0	103,0	103,0	80,0	80,0
18	124,0	124,0	95,0	95,0	74,5	74,5	124,0	124,0	97,0	97,0	76,0	76,0
20	116,0	116,0	89,5	89,5	71,0	71,0	120,0	121,0	91,5	91,5	72,5	72,5
22	108,0	109,0	84,5	84,5	68,0	68,0	112,0	113,0	87,0	87,0	69,5	69,5
24	101,0	102,0	80,0	80,0	65,0	65,0	105,0	106,0	82,5	82,5	66,5	66,5
26	95,5	96,0	76,0	76,0	62,0	62,0	99,5	100,0	78,5	78,5	63,5	63,5
28	90,0	90,5	72,5	72,5	59,5	59,5	94,0	94,5	75,0	75,0	61,5	61,5
30	85,5	85,5	69,5	69,5	57,5	57,5	89,5	89,5	72,0	72,0	59,0	59,0
34	77,5	77,8	63,5	64,1	53,5	53,5	81,0	81,5	66,0	66,3	55,0	55,0
38	70,5	71,0	59,0	59,3	50,0	50,0	74,0	74,5	61,5	61,3	51,5	51,6
42	65,0	65,0	55,0	55,0	47,2	47,2	68,0	68,5	57,0	57,0	48,8	48,8
46	60,0	60,3	51,5	51,6	44,7	44,7	63,0	63,5	53,5	53,6	46,2	46,2
50	56,0	56,1	48,7	48,7	42,4	42,5	59,0	59,1	50,5	50,6	43,9	43,9
54	52,5	52,5	46,1	46,1	40,5	40,5	55,5	55,5	48,0	48,0	41,9	41,9
58	49,8	49,8	43,8	43,9	38,8	38,8	52,0	52,5	45,7	45,7	40,1	40,1
62	47,1	47,3	41,9	41,9	37,3	37,3	49,5	49,7	43,6	43,6	38,6	38,6
66	44,8	44,9	40,2	40,2	36,1	36,1	47,1	47,2	41,8	41,8	37,2	37,2
70	42,9	42,9	38,7	38,8	35,1	35,1	44,9	45,0	40,2	40,2	36,1	36,1
73	41,6	41,6	37,8	37,8	34,5	34,5	43,5	43,5	39,1	39,2	35,3	35,3
74	41,2	41,2	37,5	37,5	34,3	-	43,1	43,1	38,8	38,9	35,1	35,1
76	40,4	40,5	37,0	37,0	34,0	-	42,2	42,3	38,2	38,3	34,7	34,7
78	-	-	-	-	-	-	41,4	41,5	37,7	37,7	34,3	34,3
81	-	-	-	-	-	-	40,4	40,4	36,9	36,9	33,9	-
82	-	-	-	-	-	-	-	-	-	-	33,8	-
86	-	-	-	-	-	-	-	-	-	-	-	-

### Remarks · Bemerkungen · Remarques

SSL+LF2:

SL radius 17 m on request · SL-Radius 17 m auf Anfrage · rayon SL 17 m sur demande

Max. capacities with minimum counterweight · Maximale Tragfähigkeiten bei Mindestgegengewicht · Capacités maximales avec contrepoids minimum.

For HSSL+LF2 a boom power-kit is required

Für HSSL+LF2 ist ein Ausleger-Verstärkungs-Kit erforderlich

Un kit à fortifier de flèche principale est nécessaire pour HSSL+LF2

**SSL+LF2 LIFTING CAPACITIES · TRAGFÄHIGKEITEN · CAPACITÉS DE LEVAGE**

		180 t + 60 t ZB		11-15 m		0-300 t		12 m		8,40 m		360°			DIN/ISO				
		84 m						90 m			96 m								
		SSL		HSSL		SSL		HSSL		SSL		HSSL							
		10°		15°		20°		10°		15°		20°		10°		15°		20°	
m	t	t	t	t	t	t	t	t	t	t	t	t	t	t	t	t	t	t	t
13	125,0	125,0	-	-	-	-	-	-	-	-	-	-	-	-	-	-	-	-	-
14	125,0	125,0	108,0	112,0	-	-	-	125,0	-	-	-	125,0	-	-	125,0	-	-	-	-
15	125,0	125,0	108,0	108,5	81,0	83,0	-	125,0	110,0	-	-	125,0	111,0	-	125,0	111,0	-	-	-
16	125,0	125,0	105,0	105,0	81,0	81,0	-	125,0	107,0	82,0	-	125,0	108,0	82,5	125,0	108,0	82,5	-	-
18	125,0	125,0	99,0	99,0	77,0	77,0	-	125,0	101,0	78,0	-	125,0	103,0	79,0	125,0	103,0	79,0	-	-
20	124,0	123,0	94,0	94,0	74,0	74,0	-	124,0	96,0	75,0	-	125,0	97,5	76,0	125,0	97,5	76,0	-	-
22	116,0	117,0	89,0	89,0	70,5	70,5	-	121,0	91,0	72,0	-	124,0	93,0	73,0	124,0	93,0	73,0	-	-
24	109,0	110,0	85,0	85,0	68,0	68,0	-	114,0	87,0	69,0	-	117,0	89,0	70,0	117,0	89,0	70,0	-	-
26	103,0	104,0	81,0	81,0	65,0	65,0	-	107,0	83,0	66,5	-	111,0	85,0	67,5	111,0	85,0	67,5	-	-
28	98,0	98,5	77,5	77,5	62,5	62,5	-	102,0	79,5	64,0	-	105,0	81,5	65,5	105,0	81,5	65,5	-	-
30	93,0	93,5	74,0	74,0	60,5	60,5	-	97,0	76,0	62,0	-	100,0	78,0	63,0	100,0	78,0	63,0	-	-
34	84,5	85,1	68,5	68,6	56,5	56,5	-	88,3	70,6	58,0	-	91,6	72,6	59,3	91,6	72,6	59,3	-	-
38	77,5	77,8	63,5	63,8	53,0	53,0	-	80,8	65,8	54,5	-	84,1	67,6	55,8	84,1	67,6	55,8	-	-
42	71,5	71,5	59,5	59,5	50,0	50,0	-	74,5	61,5	51,5	-	77,5	63,0	52,5	77,5	63,0	52,5	-	-
46	66,0	66,5	55,5	55,8	47,6	47,6	-	69,5	57,8	48,9	-	72,1	59,6	50,1	72,1	59,6	50,1	-	-
50	62,0	62,0	52,5	52,6	45,3	45,3	-	64,8	54,5	46,6	-	67,3	56,3	47,9	67,3	56,3	47,9	-	-
54	58,0	58,0	49,9	49,9	43,2	43,2	-	60,5	51,5	44,5	-	63,0	53,0	45,7	63,0	53,0	45,7	-	-
58	54,5	54,6	47,4	47,5	41,4	41,4	-	57,1	49,1	42,6	-	59,6	50,7	43,8	59,6	50,7	43,8	-	-
62	51,5	51,8	45,3	45,3	39,8	39,7	-	54,1	46,9	40,9	-	56,5	48,5	42,1	56,5	48,5	42,1	-	-
66	49,3	49,4	43,4	43,4	38,3	38,3	-	51,5	44,9	39,4	-	53,5	46,4	40,5	53,5	46,4	40,5	-	-
70	47,0	47,2	41,7	41,7	37,1	37,1	-	49,2	43,1	38,1	-	51,1	44,6	39,1	51,1	44,6	39,1	-	-
74	45,0	45,1	40,2	40,2	36,0	36,0	-	47,1	41,5	37,0	-	49,0	42,9	37,9	49,0	42,9	37,9	-	-
78	43,2	43,3	38,9	38,9	35,1	35,1	-	45,1	40,1	36,0	-	47,0	41,4	36,8	47,0	41,4	36,8	-	-
82	41,7	41,3	37,8	37,8	34,4	34,4	-	42,1	38,9	35,1	-	43,5	39,4	35,9	43,5	39,4	35,9	-	-
83	40,9	40,6	37,5	37,5	34,2	34,2	-	41,3	38,6	34,9	-	42,6	38,9	35,7	42,6	38,9	35,7	-	-
86	38,5	38,3	36,9	36,9	33,8	-	-	38,9	37,2	34,4	-	39,8	36,9	34,4	39,8	36,9	34,4	-	-
87	-	-	36,7	36,7	33,7	-	-	38,0	36,6	34,2	-	38,8	36,1	33,8	38,8	36,1	33,8	-	-
88	-	-	-	-	-	-	-	37,2	36,0	34,1	-	37,8	35,4	33,3	37,8	35,4	33,3	-	-
90	-	-	-	-	-	-	-	35,5	34,8	-	-	35,8	33,9	32,2	35,8	33,9	32,2	-	-
91	-	-	-	-	-	-	-	34,6	34,2	-	-	34,8	33,1	31,6	34,8	33,1	31,6	-	-
92	-	-	-	-	-	-	-	-	33,7	-	-	33,8	32,4	31,1	33,8	32,4	31,1	-	-
94	-	-	-	-	-	-	-	-	-	-	-	31,8	30,8	-	31,8	30,8	-	-	-
97	-	-	-	-	-	-	-	-	-	-	-	28,8	28,6	-	28,8	28,6	-	-	-

**Remarks · Bemerkungen · Remarques**

SSL+LF2:

SL radius 17 m on request · SL-Radius 17 m auf Anfrage · rayon SL 17 m sur demande

Max. capacities with minimum counterweight · Maximale Tragfähigkeiten bei Mindestgegengewicht · Capacités maximales avec contrepoids minimum.

For HSSL+LF2 a boom power-kit is required

Für HSSL+LF2 ist ein Ausleger-Verstärkungs-Kit erforderlich

Un kit à fortifier de flèche principale est nécessaire pour HSSL+LF2

## SSL+LF2 LIFTING CAPACITIES · TRAGFÄHIGKEITEN · CAPACITÉS DE LEVAGE

180 t + 60 t ZB 11-15 m 0-300 t 12 m 8,4 m 360° DIN/ISO

m	102 m			108 m		
	HSSL			HSSL		
	10°	15°	20°	10°	15°	20°
15	125,0	-	-	123,0	-	-
16	125,0	110,0	-	123,0	111,0	-
17	125,0	107,0	81,5	123,0	108,5	82,5
18	125,0	104,0	80,0	123,0	106,0	81,0
20	125,0	99,5	77,0	123,0	101,0	77,5
22	125,0	95,0	74,0	123,0	96,5	75,0
24	120,0	90,5	71,5	123,0	92,5	72,0
26	114,0	87,0	69,0	117,0	88,5	70,0
28	108,0	83,5	66,5	111,0	85,0	67,5
30	103,0	80,0	64,5	106,0	82,0	65,5
34	94,6	74,3	60,5	97,6	76,3	61,5
38	87,1	69,3	57,0	90,0	71,1	58,0
42	80,5	65,0	54,0	83,0	66,5	55,0
46	74,8	61,3	51,3	77,6	62,8	52,3
50	69,8	58,0	48,9	72,6	59,5	49,9
54	65,5	55,0	46,8	68,0	56,5	47,9
58	61,8	52,3	44,9	64,3	53,8	45,9
62	58,5	49,9	43,2	61,0	51,4	44,2
66	55,5	47,9	41,6	58,0	49,4	42,6
70	53,1	46,0	40,2	54,2	47,4	41,1
74	50,8	44,3	38,9	50,8	45,6	39,8
78	48,5	42,7	37,7	47,4	44,0	38,6
82	44,7	40,8	36,7	43,8	42,5	37,5
86	40,8	38,3	35,0	40,3	40,0	35,9
90	37,0	35,1	32,5	36,7	36,6	33,2
94	33,2	31,9	30,1	33,1	33,1	30,4
97	30,2	29,4	28,2	30,5	30,5	28,4
98	29,3	28,6	-	29,6	29,6	27,7
102	25,5	25,4	-	26,0	26,2	24,9
106	-	-	-	22,4	22,6	-
107	-	-	-	21,6	21,8	-

### Remarks · Bemerkungen · Remarques

SSL+LF2:

SL radius 17 m on request · SL-Radius 17 m auf Anfrage · rayon SL 17 m sur demande

Max. capacities with minimum counterweight · Maximale Tragfähigkeiten bei Mindestgegengewicht · Capacités maximales avec contrepoids minimum.

For HSSL+LF2 a boom power-kit is required

Für HSSL+LF2 ist ein Ausleger-Verstärkungs-Kit erforderlich

Un kit à fortifier de flèche principale est nécessaire pour HSSL+LF2

**SSL/LSL+LF2 LIFTING CAPACITIES · TRAGFÄHIGKEITEN ·  
 CAPACITÉS DE LEVAGE**

180 t + 60 t ZB		11-15 m		0-300 t		12 m		8,40 m		360°		DIN/ISO	
m	90 m						96 m						
	SSL/LSL+LF2		SSL/LSL+LF2 SGLmax.		SSL/LSL+LF2		SSL/LSL+LF2 SGLmax.		SSL/LSL+LF2		SSL/LSL+LF2 SGLmax.		
	10°		15°		20°		10°		15°		20°		
t	t	t	t	t	t	t	t	t	t	t	t	t	
14	125,0	125,0	-	-	-	-	-	-	-	-	-	-	
15	125,0	125,0	108,0	122,0	-	-	124,0	125,0	-	-	-	-	
16	125,0	125,0	108,0	118,0	80,5	90,5	124,0	125,0	106,0	120,0	-	-	
17	125,0	125,0	105,0	115,0	80,5	88,5	123,0	125,0	106,0	117,0	81,5	89,5	
18	125,0	125,0	102,0	112,0	79,0	86,5	123,0	125,0	104,0	114,0	80,0	87,5	
20	125,0	125,0	97,0	106,0	75,5	83,0	121,0	125,0	98,5	108,0	76,5	84,0	
22	121,0	125,0	92,0	101,0	72,5	79,5	119,0	125,0	94,0	103,0	73,5	81,0	
24	114,0	120,0	88,0	96,5	69,5	76,5	117,0	123,0	89,5	98,5	71,0	78,0	
26	107,0	113,0	84,0	92,0	67,0	74,0	111,0	117,0	86,0	94,5	68,0	75,0	
28	102,0	107,0	80,5	88,5	64,5	71,0	105,0	111,0	82,5	90,5	66,0	72,5	
30	97,0	102,0	77,0	84,5	62,5	69,0	100,0	105,0	79,0	87,0	63,5	70,0	
34	88,5	93,3	71,0	78,5	58,5	64,6	91,5	96,6	73,0	81,0	59,5	66,0	
38	81,0	85,6	66,0	73,1	55,0	60,8	84,0	89,0	68,0	75,5	56,0	62,1	
42	75,0	79,0	62,0	68,5	52,0	57,5	77,5	82,0	64,0	70,5	53,0	58,5	
46	69,5	73,6	58,0	64,5	49,3	54,5	72,5	76,6	60,0	66,5	50,5	55,8	
50	65,0	68,8	55,0	60,8	47,0	51,8	67,5	71,8	56,5	62,8	48,2	53,1	
54	61,0	64,5	52,0	57,5	44,8	49,6	63,5	67,5	54,0	59,5	46,0	50,5	
58	57,5	61,1	49,7	54,8	42,9	47,6	60,0	63,5	51,0	56,5	44,1	48,7	
62	54,5	58,0	47,4	52,3	41,3	45,7	56,5	60,0	49,0	53,8	42,4	47,0	
66	51,5	55,0	45,3	50,0	39,8	44,1	54,0	57,0	46,9	51,5	40,8	45,3	
70	49,5	52,3	43,5	48,2	38,4	42,6	51,5	54,3	45,0	49,7	39,5	43,7	
74	47,3	50,0	41,9	46,5	37,3	41,3	49,2	52,0	43,3	48,0	38,2	42,4	
78	45,4	48,2	40,5	44,9	36,2	40,2	47,2	50,0	41,8	46,3	37,1	41,2	
82	43,7	45,5	39,3	43,5	35,4	39,2	45,4	47,0	40,5	44,1	36,2	40,1	
86	41,9	42,1	38,2	40,9	34,6	38,4	42,7	43,3	39,3	41,5	35,3	38,6	
88	40,0	40,4	37,7	39,5	34,3	38,1	40,9	41,5	38,2	40,0	34,9	37,6	
90	38,2	38,7	37,3	38,2	34,1	-	39,2	39,7	37,2	38,5	34,6	36,6	
92	36,3	37,0	36,3	36,8	33,8	-	37,4	37,9	35,9	37,0	34,2	35,5	
93	-	-	-	-	-	-	36,5	37,0	35,3	36,2	34,0	35,0	
94	-	-	-	-	-	-	35,7	36,1	34,7	35,5	33,8	-	
97	-	-	-	-	-	-	33,1	33,3	32,8	33,2	32,4	-	
98	-	-	-	-	-	-	-	-	-	-	32,0	-	
102	-	-	-	-	-	-	-	-	-	-	-	-	



**Remarks · Bemerkungen · Remarques**

SSL/LSL+LF2:

SL radius 17 m on request · SL-Radius 17 m auf Anfrage · rayon SL 17 m sur demande

Max. capacities with minimum counterweight · Maximale Tragfähigkeiten bei Mindestgegengewicht · Capacités maximales avec contrepoids minimum.

For SSL/LSL+LF2 SGLmax. a boom power-kit is required

Für SSL/LSL+LF2 SGLmax. ist ein Ausleger-Verstärkungs-Kit erforderlich

Un kit à fortifier de flèche principale est nécessaire pour SSL/LSL+LF2 SGLmax.

## SSL/LSL+LF2 LIFTING CAPACITIES · TRAGFÄHIGKEITEN · CAPACITÉS DE LEVAGE

180 t + 60 t ZB 11-15 m 0-300 t 12 m 8,40 m 360° DIN/ISO

m	102 m						108 m						
	SSL/LSL+LF2		SSL/LSL+LF2 SGLmax.		SSL/LSL+LF2		SSL/LSL+LF2		SSL/LSL+LF2 SGLmax.		SSL/LSL+LF2		
	10°	15°	15°	20°	20°	10°	15°	15°	20°	20°	10°	15°	
t	t	t	t	t	t	t	t	t	t	t	t	t	t
15	110,0	125,0	-	-	-	-	-	-	-	-	-	-	-
16	110,0	125,0	99,5	122,0	-	-	95,5	124,0	-	-	-	-	-
17	109,0	125,0	99,5	118,5	80,5	90,5	95,5	124,0	87,5	120,0	-	-	-
18	108,0	125,0	98,5	115,0	80,5	88,5	94,5	124,0	87,5	117,0	80,0	89,5	-
19	107,0	125,0	98,0	112,5	79,0	86,7	93,5	123,5	86,5	114,5	80,0	87,7	-
20	106,0	125,0	97,0	110,0	77,5	85,0	92,5	123,0	85,5	112,0	78,5	86,0	-
22	104,0	125,0	95,0	105,0	74,5	82,0	90,5	122,0	83,5	107,0	75,5	83,0	-
24	102,0	125,0	91,5	100,0	72,0	79,0	88,0	121,0	81,5	102,0	73,0	80,0	-
26	100,0	120,0	87,5	96,5	69,5	76,5	86,0	120,0	79,5	98,5	70,5	77,5	-
28	97,5	114,0	84,0	92,5	67,0	74,0	83,5	117,0	77,5	94,5	68,0	75,0	-
30	95,0	109,0	81,0	89,0	65,0	71,5	81,0	112,0	75,5	91,0	66,0	72,5	-
34	90,5	100,0	75,0	83,0	61,0	67,1	76,5	103,0	71,5	85,0	62,0	68,5	-
38	86,0	92,0	70,0	77,5	57,5	63,3	72,0	95,0	67,5	79,5	58,5	64,8	-
42	80,5	85,0	65,5	72,5	54,5	60,0	68,0	88,0	64,0	74,5	55,5	61,5	-
46	75,0	79,3	62,0	68,5	51,5	57,0	64,5	82,3	60,5	70,1	52,5	58,5	-
50	70,0	74,3	58,5	64,6	49,4	54,3	61,0	77,0	57,5	66,3	50,5	55,6	-
54	66,0	70,0	55,5	61,0	47,2	52,0	57,5	72,0	55,0	63,0	48,3	53,0	-
58	62,0	66,0	52,5	58,3	45,2	50,0	55,0	68,0	52,5	60,0	46,3	51,0	-
62	59,0	62,5	50,5	55,8	43,5	48,2	52,0	64,5	50,0	57,3	44,5	49,1	-
66	56,0	59,5	48,4	53,5	41,9	46,4	50,0	61,5	48,1	55,0	42,9	47,5	-
70	53,5	56,8	46,4	51,1	40,5	44,8	47,9	58,7	46,2	52,6	41,4	45,9	-
74	51,0	54,1	44,7	49,5	39,2	43,4	45,4	55,6	43,9	50,7	40,1	44,5	-
78	49,0	52,0	43,1	47,7	38,0	42,2	42,9	52,0	41,6	49,2	38,9	43,2	-
82	46,5	48,7	41,7	45,3	37,0	40,8	40,3	48,4	39,2	46,2	37,8	41,2	-
86	42,8	45,1	39,1	42,5	35,8	38,8	37,8	44,8	36,9	43,0	36,1	38,8	-
90	39,0	41,3	36,2	39,2	33,7	36,4	35,3	41,1	34,5	39,6	33,9	36,2	-
94	35,3	37,3	33,4	35,9	31,6	33,9	32,8	37,3	32,2	36,2	31,7	33,5	-
98	31,6	33,4	30,5	32,7	29,4	31,5	30,2	33,6	29,8	32,8	29,5	30,8	-
102	27,9	29,5	27,6	29,4	27,3	-	27,7	29,9	27,5	29,4	27,3	28,2	-
103	-	-	-	-	26,8	-	27,0	28,9	26,9	28,5	26,7	27,5	-
106	-	-	-	-	-	-	25,2	26,1	25,2	26,0	25,1	-	-
107	-	-	-	-	-	-	24,6	25,2	24,6	25,2	24,5	-	-
108	-	-	-	-	-	-	-	-	24,0	24,4	24,0	-	-

### Remarks · Bemerkungen · Remarques

SSL/LSL+LF2:

SL radius 17 m on request · SL-Radius 17 m auf Anfrage · rayon SL 17 m sur demande

Max. capacities with minimum counterweight · Maximale Tragfähigkeiten bei Mindestgegengewicht · Capacités maximales avec contrepoids minimum.

For SSL/LSL+LF2 SGLmax. a boom power-kit is required

Für SSL/LSL+LF2 SGLmax. ist ein Ausleger-Verstärkungs-Kit erforderlich

Un kit à fortifier de flèche principale est nécessaire pour SSL/LSL+LF2 SGLmax.



**SSL/LSL+LF2 LIFTING CAPACITIES · TRAGFÄHIGKEITEN · CAPACITÉS DE LEVAGE**

180 t + 60 t ZB 11-15 m 0-300 t 12 m 8,40 m 360° DIN/ISO

m	114 m						120 m					
	SSL/LSL+LF2		SSL/LSL+LF2 SGLmax.		SSL/LSL+LF2 SGLmax.		SSL/LSL+LF2		SSL/LSL+LF2 SGLmax.		SSL/LSL+LF2 SGLmax.	
	10°	t	15°	t	20°	t	10°	t	15°	t	20°	t
16	85,5	115,0	-	-	-	-	-	-	-	-	-	-
17	85,5	115,0	79,5	111,0	-	-	75,0	107,0	-	-	-	-
18	85,0	115,0	79,5	111,0	73,0	90,5	75,0	107,0	69,5	105,0	-	-
19	84,5	115,0	79,0	110,5	73,0	88,7	74,5	107,0	69,5	104,5	64,5	89,5
20	84,0	115,0	78,5	110,0	73,0	87,0	74,0	107,0	69,0	104,0	64,5	88,0
22	82,5	115,0	77,0	108,0	72,0	84,0	73,0	107,0	68,0	103,0	63,5	85,0
24	81,5	115,0	76,0	104,0	71,0	81,0	72,0	107,0	67,0	101,0	62,5	82,0
26	80,0	115,0	75,0	100,0	70,0	78,5	70,5	107,0	66,0	100,0	62,0	79,5
28	78,5	115,0	73,5	96,5	69,0	76,0	69,5	107,0	65,0	98,0	61,0	77,0
30	77,0	113,0	72,0	92,5	67,0	73,5	68,0	107,0	64,0	94,5	60,0	74,5
34	74,0	105,0	69,5	86,5	63,0	69,5	65,5	103,0	61,5	88,5	58,0	70,5
38	70,5	97,5	66,5	81,0	59,5	65,8	63,0	98,3	59,0	83,0	56,0	66,8
42	68,0	90,5	64,0	76,0	56,5	62,5	60,5	93,0	57,0	78,0	54,0	63,5
46	65,0	84,8	61,0	72,0	54,0	59,5	58,0	87,3	55,0	73,6	52,0	60,5
50	62,0	79,5	58,5	68,1	51,5	56,8	56,0	82,0	53,0	69,8	50,0	57,8
54	59,5	74,5	56,5	64,5	49,3	54,5	53,5	77,0	51,0	66,5	48,5	55,5
58	57,0	70,5	54,0	61,8	47,3	52,1	51,5	71,6	49,1	63,5	46,9	53,5
62	54,5	66,5	52,0	59,1	45,5	50,2	49,6	66,5	47,3	60,4	45,3	51,5
66	52,0	62,5	50,0	56,5	43,9	48,6	47,7	61,5	45,5	57,0	43,7	49,6
70	50,0	57,7	48,1	54,2	42,4	47,0	45,8	56,5	43,9	54,0	42,3	48,0
74	47,7	53,8	46,1	52,1	41,0	45,5	44,0	51,9	42,3	51,2	40,9	46,5
78	44,9	50,5	43,5	50,5	39,8	44,1	41,9	47,8	40,5	48,6	39,3	45,1
82	42,2	47,1	41,0	47,3	38,6	42,5	39,6	43,6	38,3	45,4	37,3	43,8
86	39,5	43,7	38,4	44,0	37,5	40,3	37,3	39,7	36,1	42,3	35,2	42,0
90	36,7	40,3	35,9	40,5	35,0	37,4	34,9	35,9	34,0	39,1	33,1	38,9
94	34,0	36,8	33,3	37,0	32,6	34,4	32,6	32,4	31,8	35,9	31,1	35,7
98	31,3	33,3	30,8	33,6	30,2	31,5	30,3	29,1	29,6	32,7	29,0	32,6
102	28,5	29,9	28,2	30,2	27,8	28,6	27,9	26,1	27,4	29,6	26,9	29,5
106	25,8	26,4	25,6	26,7	25,4	25,6	25,6	23,3	25,2	26,4	24,9	26,4
108	24,5	24,7	24,4	25,0	24,2	24,2	24,4	21,9	24,1	24,8	23,8	24,8
110	23,1	23,0	23,1	23,2	23,0	-	23,3	20,6	23,0	23,2	22,8	23,2
112	21,7	21,2	21,8	21,5	21,8	-	22,1	19,4	21,9	21,6	21,8	21,7
113	21,0	20,4	21,2	20,7	21,2	-	21,5	18,8	21,3	20,8	21,2	-
114	-	-	-	-	-	-	20,9	18,2	20,8	20,1	20,7	-
118	-	-	-	-	-	-	18,6	16,1	18,6	16,9	18,7	-



**Remarks · Bemerkungen · Remarques**

SSL/LSL+LF2:

SL radius 17 m on request · SL-Radius 17 m auf Anfrage · rayon SL 17 m sur demande

Max. capacities with minimum counterweight · Maximale Tragfähigkeiten bei Mindestgegengewicht · Capacités maximales avec contrepoids minimum.

For SSL/LSL+LF2 SGLmax. a boom power-kit is required

Für SSL/LSL+LF2 SGLmax. ist ein Ausleger-Verstärkungs-Kit erforderlich

Un kit à fortifier de flèche principale est nécessaire pour SSL/LSL+LF2 SGLmax.

## SSL/LSL+LF2 LIFTING CAPACITIES · TRAGFÄHIGKEITEN · CAPACITÉS DE LEVAGE

180 t + 60 t ZB 11-15 m 0-300 t 12 m 8,40 m 360° DIN/ISO

m	126 m						132 m					
	SSL/LSL+LF2		SSL/LSL+LF2 SGLmax.		SSL/LSL+LF2		SSL/LSL+LF2		SSL/LSL+LF2 SGLmax.		SSL/LSL+LF2	
	10°	15°	15°	20°	20°	20°	10°	15°	15°	20°	20°	20°
t	t	t	t	t	t	t	t	t	t	t	t	t
17	65,5	97,5	-	-	-	-	-	-	-	-	-	-
18	65,5	97,5	61,0	96,5	-	-	60,0	90,5	-	-	-	-
19	65,5	97,5	61,0	96,5	57,0	90,0	60,0	90,5	57,0	89,5	-	-
20	65,0	97,5	61,0	96,5	57,0	88,5	60,0	90,5	57,0	89,5	53,5	86,5
21	64,5	97,5	60,5	96,2	57,0	87,0	59,5	90,2	56,5	89,5	53,5	86,5
22	64,0	97,5	60,0	96,0	56,5	85,5	59,0	90,0	56,0	89,5	53,0	86,5
24	63,0	97,5	59,0	96,0	55,5	83,0	58,5	90,0	55,5	89,0	52,5	83,5
26	62,0	97,5	58,0	95,5	54,5	80,5	58,0	89,5	55,0	89,0	52,0	81,0
28	61,0	97,5	57,0	95,0	54,0	78,0	57,0	89,5	54,5	89,0	51,5	79,0
30	60,0	97,5	56,5	95,0	53,0	75,5	56,5	89,0	53,5	88,5	51,0	76,5
34	57,5	95,8	54,0	89,6	51,0	71,5	55,0	87,6	52,0	87,5	49,7	72,5
38	55,5	93,8	52,0	84,5	49,5	67,8	53,0	86,0	50,5	85,0	48,3	68,8
42	53,0	91,5	50,0	79,5	47,7	64,5	51,5	84,0	49,4	81,0	47,0	65,5
46	51,0	86,8	48,5	75,1	46,0	61,8	50,0	80,6	47,9	77,0	45,6	62,8
50	49,2	81,5	46,6	71,3	44,3	59,1	48,8	76,5	46,6	73,1	44,4	60,1
54	47,2	75,5	44,9	68,0	42,8	56,5	47,4	71,5	45,3	69,5	43,2	57,5
58	45,3	70,1	43,2	65,0	41,3	54,5	45,9	66,5	43,9	65,8	42,0	55,5
62	43,5	65,0	41,6	62,0	39,8	52,5	44,5	61,6	42,6	61,8	40,9	53,5
66	41,8	60,0	40,0	58,0	38,4	50,5	43,0	57,0	41,3	57,0	39,7	51,5
70	40,2	55,0	38,6	54,0	37,1	48,9	41,6	52,3	40,0	52,6	38,5	49,1
74	38,6	50,4	37,2	50,1	35,9	47,3	40,2	48,2	38,7	48,5	37,3	46,5
78	37,2	46,2	35,8	46,4	34,7	45,6	38,7	44,2	37,4	44,6	36,1	43,6
82	35,4	42,1	34,2	42,8	33,3	43,3	37,3	40,4	36,0	40,8	34,9	40,8
83	34,9	41,1	33,7	41,9	32,8	42,6	-	39,4	-	39,8	34,6	40,1
86	33,4	38,2	32,4	39,3	31,6	40,4	-	36,7	-	37,1	-	38,0
90	31,5	34,4	30,6	35,9	29,9	37,5	-	33,1	-	33,5	-	35,3
94	29,6	31,0	28,8	32,7	28,1	34,5	-	29,7	-	30,2	-	32,6
98	27,6	27,7	27,0	29,5	26,4	31,6	-	26,6	-	27,0	-	29,9
102	25,7	24,6	25,2	26,5	24,7	28,7	-	23,6	-	24,0	-	27,2
106	23,8	21,8	23,4	23,7	23,0	25,7	-	20,8	-	21,2	-	24,5
110	21,9	19,2	21,6	20,9	21,3	22,8	-	18,2	-	18,6	-	21,8
114	19,9	16,8	19,8	18,3	19,6	19,9	-	15,8	-	16,1	-	19,1
117	18,4	15,2	18,3	16,4	18,3	17,7	-	14,1	-	14,4	-	17,1
118	18,0	14,7	17,9	15,7	17,9	-	-	13,5	-	13,8	-	16,4
122	16,1	12,7	16,1	13,4	16,1	-	-	11,4	-	11,7	-	13,7
123	15,6	12,3	15,7	12,8	15,7	-	-	10,9	-	11,2	-	-
126	-	-	-	-	-	-	-	9,5	-	9,7	-	-
128	-	-	-	-	-	-	-	8,7	-	8,8	-	-
130	-	-	-	-	-	-	-	-	-	-	-	-

### Remarks · Bemerkungen · Remarques

SSL/LSL+LF2:

SL radius 17 m on request · SL-Radius 17 m auf Anfrage · rayon SL 17 m sur demande

Max. capacities with minimum counterweight · Maximale Tragfähigkeiten bei Mindestgegengewicht · Capacités maximales avec contrepoids minimum.

For SSL/LSL+LF2 SGLmax. a boom power-kit is required

Für SSL/LSL+LF2 SGLmax. ist ein Ausleger-Verstärkungs-Kit erforderlich

Un kit à fortifier de flèche principale est nécessaire pour SSL/LSL+LF2 SGLmax.

**SSL/LSL+LF2 LIFTING CAPACITIES · TRAGFÄHIGKEITEN · CAPACITÉS DE LEVAGE**

180 t + 60 t ZB 11-15 m 0-300 t 12 m 8,40 m 360° DIN/ISO

m	138 m					
	SSL/LSL+LF2		SSL/LSL+LF2		SSL/LSL+LF2	
	LF2	SGLmax.	LF2	SGLmax.	LF2	SGLmax.
	10°		15°		20°	
t	t	t	t	t	t	
18	50,0	79,5	-	-	-	-
19	50,0	79,5	50,5	79,0	-	-
20	50,0	79,5	50,5	79,0	48,0	78,0
21	49,9	79,2	50,5	79,0	48,0	78,0
22	49,8	79,0	50,0	79,0	48,0	78,0
24	49,2	78,5	49,9	78,5	47,6	77,5
26	48,6	78,0	49,4	78,0	47,2	77,0
28	48,0	77,5	49,0	77,5	46,8	77,0
30	47,4	77,0	48,5	77,0	46,4	76,5
34	46,2	76,0	47,5	76,0	45,5	73,1
38	44,9	75,0	46,5	75,0	44,6	69,8
42	43,6	74,0	45,5	74,0	43,7	66,5
46	42,3	72,3	44,4	72,6	42,8	63,5
50	39,6	69,3	42,2	69,8	41,3	60,8
54	36,9	65,0	39,6	65,5	39,2	58,5
58	34,2	60,8	37,0	61,0	37,2	56,1
62	31,5	56,5	34,4	57,0	35,1	53,8
66	28,8	52,5	31,8	53,0	33,1	51,5
70	26,1	48,8	29,2	49,2	31,0	48,1
74	23,4	45,1	26,6	45,5	29,0	44,9
78	20,7	41,5	24,0	41,9	26,9	41,6
82	18,0	38,0	21,3	38,4	24,9	38,4
84	16,6	36,3	20,0	36,7	23,8	36,9
85	-	35,4	19,4	35,8	23,3	36,1
86	-	34,6	-	35,0	22,8	35,3
90	-	31,4	-	31,8	-	32,3
94	-	28,3	-	28,7	-	29,4
98	-	25,3	-	25,7	-	26,6
102	-	22,5	-	22,8	-	23,9
106	-	19,8	-	20,1	-	21,2
110	-	17,2	-	17,5	-	18,6
114	-	14,8	-	15,1	-	16,2
118	-	12,6	-	12,8	-	13,8
122	-	10,4	-	10,6	-	11,5
126	-	8,4	-	8,6	-	9,3
127	-	7,9	-	8,1	-	8,8
130	-	6,5	-	6,7	-	-
133	-	5,2	-	5,3	-	-
134	-	-	-	4,9	-	-

**Remarks · Bemerkungen · Remarques**

SSL/LSL+LF2:

SL radius 17 m on request · SL-Radius 17 m auf Anfrage · rayon SL 17 m sur demande

Max. capacities with minimum counterweight · Maximale Tragfähigkeiten bei Mindestgegengewicht · Capacités maximales avec contrepoids minimum.

For SSL/LSL+LF2 SGLmax. a boom power-kit is required

Für SSL/LSL+LF2 SGLmax. ist ein Ausleger-Verstärkungs-Kit erforderlich

Un kit à fortifier de flèche principale est nécessaire pour SSL/LSL+LF2 SGLmax.

**SW WORKING RANGES · ARBEITSBEREICHE · PORTÉES**

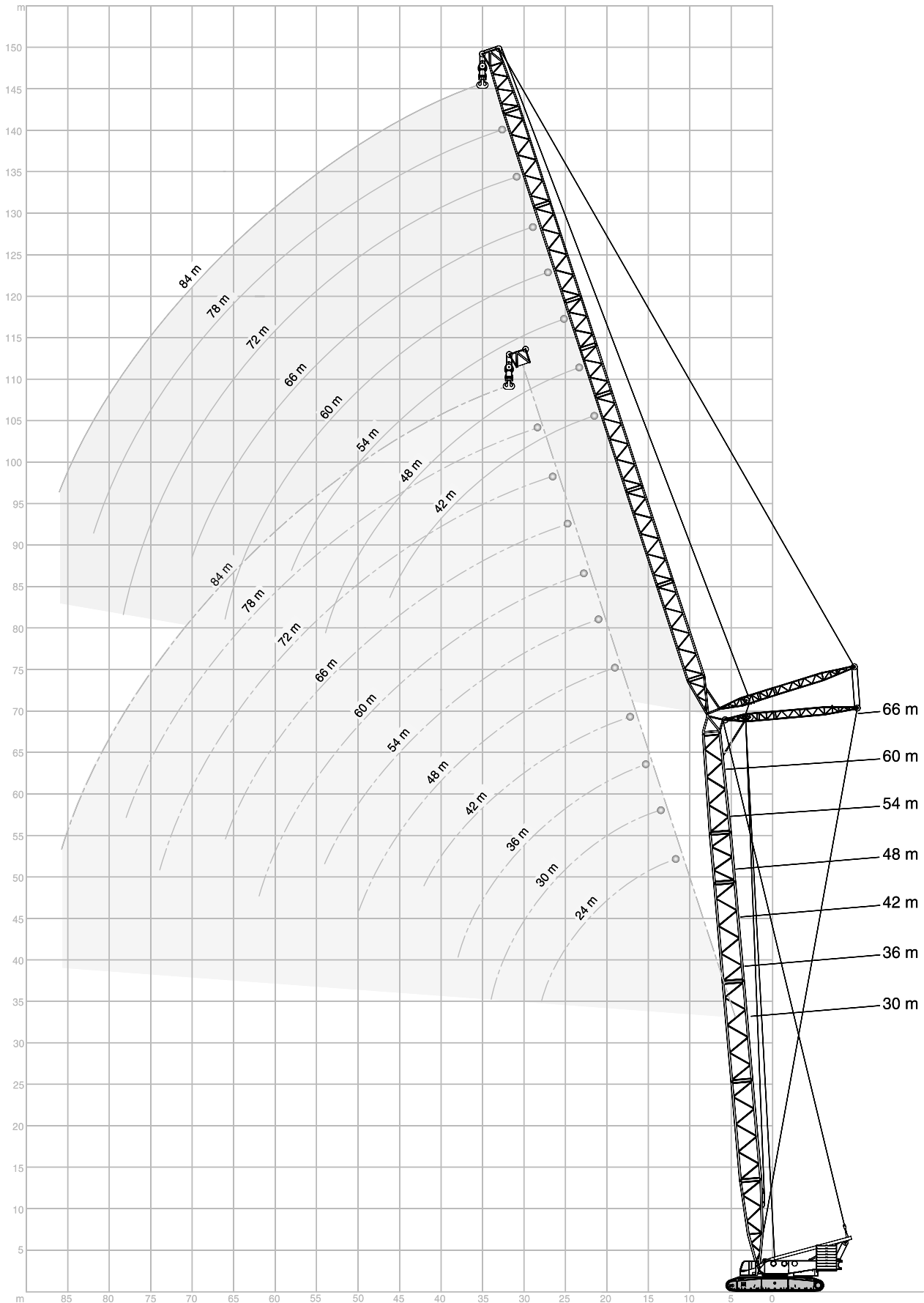

**SW LIFTING CAPACITIES · TRAGFÄHIGKEITEN · CAPACITÉS DE LEVAGE**

180 t + 60 t ZB 8,40 m 360° DIN/ISO

30 m

m	24 m			30 m			36 m			42 m			48 m			54 m		
	85°	75°	65°	85°	75°	65°	85°	75°	65°	85°	75°	65°	85°	75°	65°	85°	75°	65°
14	t	t	t	t	t	t	t	t	t	t	t	t	t	t	t	t	t	t
16	208,0	-	-	-	-	-	-	-	-	-	-	-	-	-	-	-	-	-
18	172,0	-	-	171,0	-	-	-	-	-	-	-	-	-	-	-	-	-	-
20	145,0	-	-	144,0	-	-	144,0	-	-	-	-	-	-	-	-	-	-	-
22	126,0	-	-	125,0	-	-	124,0	-	-	123,0	-	-	-	-	-	-	-	-
24	111,0	-	-	110,0	-	-	109,0	-	-	108,0	-	-	107,0	-	-	-	-	-
26	98,5	92,5	-	98,0	-	-	97,0	-	-	96,0	-	-	95,5	-	-	94,0	-	-
28	89,0	83,0	-	88,0	82,0	-	87,5	-	-	86,0	-	-	85,5	-	-	84,5	-	-
30	80,5	75,5	-	80,0	74,5	-	79,0	-	-	78,0	-	-	77,5	-	-	76,0	-	-
32	-	69,0	-	73,0	68,0	-	72,0	67,0	-	71,0	-	-	70,5	-	-	69,5	-	-
34	-	63,5	59,0	67,5	62,5	-	66,5	61,5	-	65,5	60,0	-	65,0	-	-	64,0	-	-
36	-	-	54,5	62,0	57,5	-	61,0	56,5	-	60,0	55,5	-	59,5	54,5	-	58,5	-	-
38	-	-	50,5	-	53,5	49,5	56,7	52,5	-	55,7	51,0	-	55,2	50,5	-	54,2	-	-
40	-	-	47,2	-	49,8	46,1	52,5	48,8	-	51,5	47,7	-	51,0	46,8	-	50,0	45,6	-
42	-	-	-	-	-	43,0	-	45,6	41,8	48,4	44,4	-	47,7	43,6	-	46,7	42,3	-
44	-	-	-	-	-	40,3	-	42,7	39,1	45,3	41,5	-	44,5	40,7	-	43,4	39,4	-
46	-	-	-	-	-	-	-	40,0	36,6	-	38,9	35,5	41,8	38,1	-	40,7	36,8	-
48	-	-	-	-	-	-	-	-	34,4	-	36,6	33,3	39,2	35,7	32,3	38,1	34,5	-
50	-	-	-	-	-	-	-	-	30,7	-	32,5	29,5	34,9	31,6	28,5	33,7	30,4	27,1
52	-	-	-	-	-	-	-	-	-	-	-	26,3	-	28,2	25,3	30,1	27,0	23,8
54	-	-	-	-	-	-	-	-	-	-	-	-	-	26,8	23,8	-	25,5	22,3
56	-	-	-	-	-	-	-	-	-	-	-	-	-	-	22,5	-	24,2	21,0
58	-	-	-	-	-	-	-	-	-	-	-	-	-	-	-	-	21,7	18,6
60	-	-	-	-	-	-	-	-	-	-	-	-	-	-	-	-	-	16,6

m	60 m			66 m			72 m			78 m			84 m		
	85°	75°	65°	85°	75°	65°	85°	75°	65°	85°	75°	65°	85°	75°	65°
26	t	t	t	t	t	t	t	t	t	t	t	t	t	t	t
28	83,5	-	-	-	-	-	-	-	-	-	-	-	-	-	-
30	75,5	-	-	75,0	-	-	-	-	-	-	-	-	-	-	-
34	68,5	-	-	68,0	-	-	67,0	-	-	-	-	-	-	-	-
38	57,5	-	-	57,0	-	-	56,0	-	-	55,5	-	-	54,5	-	-
40	49,4	-	-	48,7	-	-	47,5	-	-	47,3	-	-	46,4	-	-
42	46,0	41,5	-	45,4	-	-	44,2	-	-	44,0	-	-	43,0	-	-
44	42,7	38,6	-	42,1	-	-	40,9	-	-	40,7	-	-	39,7	-	-
46	40,0	36,0	-	39,4	35,2	-	38,2	-	-	38,0	-	-	37,0	-	-
48	37,4	33,7	-	36,7	32,9	-	35,6	31,6	-	35,3	-	-	34,4	-	-
50	33,0	29,6	-	32,3	28,8	-	31,2	27,5	-	30,9	27,0	-	30,0	-	-
52	31,1	27,8	-	30,5	27,0	-	29,3	25,6	-	29,0	25,2	-	28,1	24,0	-
54	29,3	26,2	22,7	28,7	25,3	-	27,5	23,9	-	27,2	23,5	-	26,3	22,3	-
56	26,3	23,2	19,9	25,6	22,3	18,9	24,4	20,8	-	24,1	20,4	-	23,0	19,2	-
62	23,6	20,6	17,5	22,9	19,7	16,5	21,6	18,2	15,0	21,3	17,8	-	20,2	16,6	-
66	-	18,4	15,5	20,6	17,5	14,5	19,2	16,0	13,0	18,8	15,5	12,4	17,7	14,4	-
68	-	17,4	14,6	-	16,5	13,6	18,1	15,0	12,0	17,7	14,5	11,5	16,6	13,4	-
70	-	-	13,7	-	15,5	12,7	17,1	14,1	11,2	16,6	13,6	10,7	15,6	12,4	9,4
74	-	-	-	-	13,9	11,2	15,3	12,4	9,6	14,8	11,9	9,1	13,7	10,7	7,8
78	-	-	-	-	-	9,9	-	10,9	8,3	13,2	10,4	7,7	12,0	9,2	6,5
80	-	-	-	-	-	-	-	10,3	7,7	-	9,7	7,1	11,3	8,5	5,8
82	-	-	-	-	-	-	-	-	7,1	-	9,0	6,5	10,6	7,8	5,2
84	-	-	-	-	-	-	-	-	-	-	8,4	5,9	9,9	7,2	4,7
86	-	-	-	-	-	-	-	-	-	-	-	5,4	9,3	6,7	4,2
90	-	-	-	-	-	-	-	-	-	-	-	4,5	-	5,6	-
94	-	-	-	-	-	-	-	-	-	-	-	-	-	-	-

**Remarks · Bemerkungen · Remarques**

Main boom angle 85°, 75° and 65°, capacities for intermediate boom positions are calculated by the crane control system IC-1  
 Hauptauslegerwinkel 85°, 75° und 65°, Traglasten für Zwischenstellungen des Hauptauslegers werden von der Kransteuerung IC-1 berechnet  
 Jarret de flèche principale 85°, 75° et 65°, le système de commande de la grue IC-1 calcule les charges pour les positions intermédiaires de la flèche

# SW LIFTING CAPACITIES · TRAGFÄHIGKEITEN · CAPACITÉS DE LEVAGE

180 t + 60 t ZB      8,40 m      360°      DIN/ISO

36 m

m	24 m			30 m			36 m			42 m			48 m			54 m		
	85°	75°	65°	85°	75°	65°	85°	75°	65°	85°	75°	65°	85°	75°	65°	85°	75°	65°
16	t	t	t	t	t	t	t	t	t	t	t	t	t	t	t	t	t	t
18	170,0	-	-	-	-	-	-	-	-	-	-	-	-	-	-	-	-	-
20	144,0	-	-	143,0	-	-	143,0	-	-	-	-	-	-	-	-	-	-	-
22	125,0	-	-	124,0	-	-	123,0	-	-	122,0	-	-	-	-	-	-	-	-
24	110,0	-	-	109,0	-	-	108,0	-	-	107,0	-	-	106,0	-	-	-	-	-
26	98,0	-	-	97,0	-	-	96,5	-	-	95,5	-	-	94,5	-	-	93,5	-	-
28	88,0	81,0	-	87,5	-	-	86,5	-	-	85,5	-	-	85,0	-	-	83,5	-	-
30	80,0	73,5	-	79,0	72,5	-	78,5	-	-	77,5	-	-	76,5	-	-	75,5	-	-
34	-	67,0	-	72,5	66,0	-	71,5	65,0	-	70,5	-	-	70,0	-	-	68,5	-	-
36	-	57,0	52,0	61,0	56,0	-	60,5	54,5	-	59,5	53,5	-	59,0	-	-	57,5	-	-
38	-	-	48,2	-	51,5	-	56,2	50,5	-	55,2	49,7	-	54,7	48,8	-	53,5	-	-
40	-	-	44,8	-	48,2	43,6	52,0	47,2	-	51,0	46,1	-	50,5	45,2	-	49,5	-	-
42	-	-	-	-	45,0	40,6	-	44,0	-	47,9	42,9	-	47,3	42,0	-	46,2	40,7	-
44	-	-	-	-	-	38,0	-	41,2	36,7	44,8	40,1	-	44,1	39,2	-	42,9	37,9	-
46	-	-	-	-	-	33,5	-	36,4	32,3	39,5	35,2	31,1	38,8	34,3	-	37,6	33,1	-
50	-	-	-	-	-	-	-	-	28,6	-	31,3	27,4	34,4	30,4	26,2	33,3	29,1	-
52	-	-	-	-	-	-	-	-	-	-	29,5	25,7	-	28,6	24,6	31,5	27,4	-
54	-	-	-	-	-	-	-	-	-	-	-	24,2	-	27,1	23,1	29,7	25,8	21,5
58	-	-	-	-	-	-	-	-	-	-	-	21,6	-	24,3	20,4	26,7	22,9	18,8
62	-	-	-	-	-	-	-	-	-	-	-	-	-	18,2	-	20,4	16,6	-
64	-	-	-	-	-	-	-	-	-	-	-	-	-	-	-	19,3	15,6	-
66	-	-	-	-	-	-	-	-	-	-	-	-	-	-	-	-	14,7	-
70	-	-	-	-	-	-	-	-	-	-	-	-	-	-	-	-	-	13,1
74	-	-	-	-	-	-	-	-	-	-	-	-	-	-	-	-	-	-

m	60 m			66 m			72 m			78 m			84 m		
	85°	75°	65°	85°	75°	65°	85°	75°	65°	85°	75°	65°	85°	75°	65°
26	t	t	t	t	t	t	t	t	t	t	t	t	t	t	t
28	83,0	-	-	-	-	-	-	-	-	-	-	-	-	-	-
30	75,0	-	-	74,0	-	-	-	-	-	-	-	-	-	-	-
34	68,0	-	-	67,5	-	-	66,0	-	-	-	-	-	-	-	-
38	57,0	-	-	56,5	-	-	55,0	-	-	55,0	-	-	54,0	-	-
42	48,8	-	-	48,1	-	-	47,0	-	-	46,7	-	-	45,8	-	-
44	42,2	37,1	-	41,6	-	-	40,4	-	-	40,2	-	-	39,2	-	-
46	39,5	34,6	-	38,9	33,7	-	37,7	-	-	37,5	-	-	36,5	-	-
48	36,9	32,3	-	36,3	31,5	-	35,1	-	-	34,8	-	-	33,9	-	-
50	34,7	30,2	-	34,1	29,4	-	32,9	27,9	-	32,6	-	-	31,7	-	-
54	32,6	28,3	-	31,9	27,4	-	30,7	25,9	-	30,5	25,4	-	29,5	-	-
58	28,9	24,8	-	28,2	23,9	-	27,1	22,4	-	26,8	22,0	-	25,9	20,8	-
62	25,9	21,9	17,8	25,2	20,9	-	24,0	19,5	-	23,6	19,0	-	22,6	17,8	-
66	23,3	19,3	15,5	22,5	18,4	14,5	21,2	16,9	-	20,8	16,5	-	19,7	15,3	-
70	-	17,2	13,6	20,2	16,2	12,5	18,8	14,8	11,0	18,4	14,3	-	17,3	13,1	-
74	-	15,4	11,9	-	14,4	10,9	16,7	12,9	9,3	16,2	12,4	8,8	15,1	11,2	-
78	-	-	10,5	-	12,8	9,4	14,9	11,2	7,8	14,4	10,7	7,3	13,3	9,5	6,0
80	-	-	-	-	-	8,2	-	9,8	6,6	12,8	9,3	6,0	11,6	8,1	4,7
82	-	-	-	-	-	-	-	9,2	6,0	-	8,6	5,4	10,9	7,4	4,1
84	-	-	-	-	-	-	-	-	5,4	-	8,0	4,8	10,2	6,8	-
86	-	-	-	-	-	-	-	-	5,0	-	7,4	4,3	9,5	6,2	-
90	-	-	-	-	-	-	-	-	4,5	-	6,9	-	8,9	5,6	-
92	-	-	-	-	-	-	-	-	-	-	-	-	-	4,6	-
	-	-	-	-	-	-	-	-	-	-	-	-	-	4,2	-

### Remarks · Bemerkungen · Remarques

Main boom angle 85°, 75° and 65°, capacities for intermediate boom positions are calculated by the crane control system IC-1  
 Hauptauslegerwinkel 85°, 75° und 65°, Traglasten für Zwischenstellungen des Hauptauslegers werden von der Kransteuerung IC-1 berechnet  
 Jarret de flèche principale 85°, 75° et 65°, le système de commande de la grue IC-1 calcule les charges pour les positions intermédiaires de la flèche

**SW LIFTING CAPACITIES · TRAGFÄHIGKEITEN · CAPACITÉS DE LEVAGE**

180 t + 60 t ZB 8,40 m 360° DIN/ISO

42 m

m	24 m			30 m			36 m			42 m			48 m			54 m		
	85°	75°	65°	85°	75°	65°	85°	75°	65°	85°	75°	65°	85°	75°	65°	85°	75°	65°
16	t	t	t	t	t	t	t	t	t	t	t	t	t	t	t	t	t	t
18	169,0	-	-	-	-	-	-	-	-	-	-	-	-	-	-	-	-	-
20	143,0	-	-	142,0	-	-	-	-	-	-	-	-	-	-	-	-	-	-
22	124,0	-	-	123,0	-	-	122,0	-	-	-	-	-	-	-	-	-	-	-
24	109,0	-	-	108,0	-	-	107,0	-	-	106,0	-	-	-	-	-	-	-	-
26	97,0	-	-	96,5	-	-	95,5	-	-	94,5	-	-	93,5	-	-	92,5	-	-
28	87,5	78,5	-	86,5	-	-	86,0	-	-	84,5	-	-	84,0	-	-	83,0	-	-
30	79,0	71,0	-	78,5	-	-	77,5	-	-	76,5	-	-	76,0	-	-	74,5	-	-
32	-	65,0	-	71,5	64,0	-	71,0	-	-	70,0	-	-	69,0	-	-	68,0	-	-
34	-	59,5	-	66,0	58,5	-	65,5	57,5	-	64,5	-	-	63,5	-	-	62,5	-	-
36	-	55,0	-	60,5	54,0	-	60,0	52,5	-	59,0	-	-	58,0	-	-	57,0	-	-
38	-	51,0	-	-	50,0	-	55,7	49,0	-	54,7	47,8	-	54,0	-	-	52,9	-	-
40	-	-	42,1	-	46,6	-	51,5	45,5	-	50,5	44,3	-	50,0	43,4	-	48,9	-	-
42	-	-	39,3	-	43,4	-	-	42,4	-	47,3	41,2	-	46,7	40,3	-	45,6	39,0	-
44	-	-	36,8	-	40,6	35,5	-	39,6	-	44,2	38,5	-	43,5	37,6	-	42,4	36,3	-
46	-	-	-	-	-	31,2	-	34,9	29,8	39,0	33,7	-	38,3	32,9	-	37,1	31,6	-
48	-	-	-	-	-	-	-	32,9	27,9	-	31,7	-	36,1	30,8	-	34,9	29,6	-
50	-	-	-	-	-	-	-	-	26,2	-	29,9	24,8	34,0	29,0	-	32,8	27,6	-
52	-	-	-	-	-	-	-	-	23,2	-	26,7	21,8	-	25,7	20,6	29,2	24,3	-
54	-	-	-	-	-	-	-	-	-	-	-	19,3	-	22,9	18,1	26,2	21,4	16,5
56	-	-	-	-	-	-	-	-	-	-	-	-	-	21,7	17,0	-	20,2	15,4
58	-	-	-	-	-	-	-	-	-	-	-	-	-	-	16,0	-	19,0	14,4
60	-	-	-	-	-	-	-	-	-	-	-	-	-	-	15,1	-	17,9	13,5
62	-	-	-	-	-	-	-	-	-	-	-	-	-	-	14,2	-	-	12,6
64	-	-	-	-	-	-	-	-	-	-	-	-	-	-	-	-	-	11,1
66	-	-	-	-	-	-	-	-	-	-	-	-	-	-	-	-	-	-
68	-	-	-	-	-	-	-	-	-	-	-	-	-	-	-	-	-	-
70	-	-	-	-	-	-	-	-	-	-	-	-	-	-	-	-	-	-
72	-	-	-	-	-	-	-	-	-	-	-	-	-	-	-	-	-	-
74	-	-	-	-	-	-	-	-	-	-	-	-	-	-	-	-	-	-

m	60 m			66 m			72 m			78 m			84 m		
	85°	75°	65°	85°	75°	65°	85°	75°	65°	85°	75°	65°	85°	75°	65°
26	t	t	t	t	t	t	t	t	t	t	t	t	t	t	t
28	82,0	-	-	-	-	-	-	-	-	-	-	-	-	-	-
30	74,0	-	-	73,5	-	-	-	-	-	-	-	-	-	-	-
32	67,0	-	-	66,5	-	-	65,5	-	-	-	-	-	-	-	-
34	56,5	-	-	55,5	-	-	54,5	-	-	54,0	-	-	53,0	-	-
36	48,2	-	-	47,5	-	-	46,4	-	-	46,1	-	-	45,2	-	-
38	41,7	-	-	41,0	-	-	39,8	-	-	39,6	-	-	38,6	-	-
40	39,0	33,0	-	38,3	-	-	37,2	-	-	36,9	-	-	36,0	-	-
42	36,4	30,7	-	35,7	29,7	-	34,6	-	-	34,3	-	-	33,4	-	-
44	32,1	26,7	-	31,4	25,7	-	30,2	24,1	-	30,0	-	-	29,0	-	-
46	30,3	24,9	-	29,6	23,9	-	28,4	22,4	-	28,1	22,0	-	27,1	-	-
48	28,5	23,3	-	27,8	22,3	-	26,6	20,8	-	26,3	20,4	-	25,3	19,1	-
50	25,4	20,4	-	24,7	19,5	-	23,5	18,0	-	23,1	17,5	-	22,0	16,3	-
52	22,8	18,0	13,3	22,1	17,0	12,3	20,7	15,5	-	20,3	15,1	-	19,2	13,9	-
54	-	15,9	11,5	19,7	14,9	10,5	18,3	13,4	8,8	17,9	13,0	-	16,8	11,8	-
56	-	14,1	9,9	17,7	13,1	8,9	16,2	11,6	7,3	15,8	11,1	6,7	14,7	9,9	-
58	-	-	8,6	-	11,6	7,5	14,4	10,0	5,9	13,9	9,5	5,4	12,8	8,3	-
60	-	-	8,0	-	10,9	6,9	-	9,3	5,3	13,1	8,8	4,7	12,0	7,6	-
62	-	-	7,4	-	-	6,3	-	8,7	4,7	12,3	8,1	4,2	11,2	6,9	-
64	-	-	-	-	-	5,8	-	8,0	4,2	-	7,5	-	10,5	6,3	-
66	-	-	-	-	-	5,3	-	7,5	-	-	6,9	-	9,8	5,7	-
68	-	-	-	-	-	-	-	-	-	-	5,8	-	8,5	4,6	-
70	-	-	-	-	-	-	-	-	-	-	5,3	-	-	4,1	-
72	-	-	-	-	-	-	-	-	-	-	-	-	-	-	-
74	-	-	-	-	-	-	-	-	-	-	-	-	-	-	-
76	-	-	-	-	-	-	-	-	-	-	-	-	-	-	-
78	-	-	-	-	-	-	-	-	-	-	-	-	-	-	-
80	-	-	-	-	-	-	-	-	-	-	-	-	-	-	-
82	-	-	-	-	-	-	-	-	-	-	-	-	-	-	-
84	-	-	-	-	-	-	-	-	-	-	-	-	-	-	-
86	-	-	-	-	-	-	-	-	-	-	-	-	-	-	-
88	-	-	-	-	-	-	-	-	-	-	-	-	-	-	-
90	-	-	-	-	-	-	-	-	-	-	-	-	-	-	-

**Remarks · Bemerkungen · Remarques**

Main boom angle 85°, 75° and 65°, capacities for intermediate boom positions are calculated by the crane control system IC-1  
 Hauptauslegerwinkel 85°, 75° und 65°, Traglasten für Zwischenstellungen des Hauptauslegers werden von der Kransteuerung IC-1 berechnet  
 Jarret de flèche principale 85°, 75° et 65°, le système de commande de la grue IC-1 calcule les charges pour les positions intermédiaires de la flèche

# SW LIFTING CAPACITIES · TRAGFÄHIGKEITEN · CAPACITÉS DE LEVAGE

180 t + 60 t ZB      8,40 m      360°      DIN/ISO

48 m

m	24 m			30 m			36 m			42 m			48 m			54 m		
	85°	75°	65°	85°	75°	65°	85°	75°	65°	85°	75°	65°	85°	75°	65°	85°	75°	65°
16	t	t	t	t	t	t	t	t	t	t	t	t	t	t	t	t	t	t
18	168,0	-	-	-	-	-	-	-	-	-	-	-	-	-	-	-	-	-
20	142,0	-	-	141,0	-	-	-	-	-	-	-	-	-	-	-	-	-	-
22	123,0	-	-	122,0	-	-	121,0	-	-	-	-	-	-	-	-	-	-	-
24	108,0	-	-	107,0	-	-	106,0	-	-	105,0	-	-	-	-	-	-	-	-
26	96,5	-	-	95,5	-	-	94,5	-	-	93,5	-	-	92,5	-	-	-	-	-
28	86,5	-	-	85,5	-	-	85,0	-	-	84,0	-	-	83,0	-	-	82,0	-	-
30	78,5	68,5	-	77,5	-	-	77,0	-	-	76,0	-	-	75,0	-	-	74,0	-	-
32	71,5	62,5	-	71,0	-	-	70,0	-	-	69,0	-	-	68,5	-	-	67,0	-	-
34	-	57,5	-	65,5	56,5	-	64,7	-	-	63,5	-	-	63,0	-	-	61,7	-	-
36	-	53,0	-	60,0	52,0	-	59,5	50,5	-	58,0	-	-	57,5	-	-	56,5	-	-
38	-	49,3	-	-	48,1	-	55,2	47,0	-	54,0	45,8	-	53,4	-	-	52,4	-	-
40	-	45,8	-	-	44,7	-	51,0	43,6	-	50,0	42,4	-	49,4	-	-	48,3	-	-
42	-	-	-	-	41,7	-	-	40,6	-	46,8	39,4	-	46,1	38,5	-	45,0	-	-
44	-	-	34,1	-	39,0	-	-	37,9	-	43,7	36,7	-	42,9	35,8	-	41,8	34,5	-
46	-	-	31,9	-	36,5	30,4	-	35,5	-	41,1	34,3	-	40,3	33,4	-	39,2	32,0	-
48	-	-	29,9	-	-	28,4	-	33,3	-	38,5	32,2	-	37,7	31,3	-	36,6	29,8	-
50	-	-	-	-	-	26,6	-	31,4	25,0	-	30,2	-	35,5	29,3	-	34,4	27,7	-
54	-	-	-	-	-	25,0	-	29,6	23,4	-	28,4	22,0	33,4	27,4	-	32,3	25,9	-
58	-	-	-	-	-	-	-	-	20,6	-	25,2	19,2	-	24,1	18,0	28,7	22,6	-
60	-	-	-	-	-	-	-	-	-	-	-	16,9	-	21,4	15,7	25,8	19,9	14,1
62	-	-	-	-	-	-	-	-	-	-	-	15,9	-	20,2	14,7	-	18,7	13,0
66	-	-	-	-	-	-	-	-	-	-	-	15,0	-	-	13,7	-	17,5	12,1
70	-	-	-	-	-	-	-	-	-	-	-	-	-	-	12,0	-	15,6	10,4
74	-	-	-	-	-	-	-	-	-	-	-	-	-	-	-	-	-	9,0
78	-	-	-	-	-	-	-	-	-	-	-	-	-	-	-	-	-	7,8

m	60 m			66 m			72 m			78 m			84 m		
	85°	75°	65°	85°	75°	65°	85°	75°	65°	85°	75°	65°	85°	75°	65°
28	t	t	t	t	t	t	t	t	t	t	t	t	t	t	t
30	73,0	-	-	-	-	-	-	-	-	-	-	-	-	-	-
34	66,5	-	-	65,5	-	-	-	-	-	-	-	-	-	-	-
38	55,5	-	-	55,0	-	-	53,5	-	-	53,5	-	-	52,5	-	-
42	47,6	-	-	46,9	-	-	45,7	-	-	45,5	-	-	44,5	-	-
46	41,1	-	-	40,4	-	-	39,2	-	-	39,0	-	-	38,0	-	-
48	35,9	28,8	-	35,2	-	-	34,0	-	-	33,8	-	-	32,8	-	-
50	33,7	26,7	-	33,0	25,7	-	31,8	-	-	31,6	-	-	30,6	-	-
54	31,6	24,9	-	30,9	23,9	-	29,7	22,3	-	29,5	-	-	28,5	-	-
56	28,0	21,6	-	27,3	20,6	-	26,1	19,1	-	25,8	18,6	-	24,7	-	-
58	26,5	20,2	-	25,8	19,2	-	24,5	17,7	-	24,2	17,2	-	23,1	16,0	-
62	25,0	18,9	-	24,3	17,9	-	22,9	16,4	-	22,6	15,9	-	21,5	14,7	-
66	22,4	16,5	11,0	21,5	15,6	-	20,2	14,0	-	19,8	13,6	-	18,7	12,3	-
70	-	14,5	9,3	19,2	13,5	8,2	17,8	12,0	-	17,4	11,6	-	16,3	10,3	-
72	-	12,8	7,8	17,2	11,8	6,8	15,7	10,3	-	15,3	9,8	-	14,2	8,6	-
74	-	12,0	7,2	-	11,0	6,1	14,8	9,5	-	14,4	9,0	-	13,3	7,8	-
76	-	-	6,6	-	10,3	5,5	14,0	8,7	-	13,5	8,3	-	12,4	7,0	-
78	-	-	5,5	-	9,0	4,4	-	7,4	-	11,9	6,9	-	10,8	5,7	-
80	-	-	-	-	-	-	-	6,3	-	10,5	5,7	-	9,3	4,5	-
82	-	-	-	-	-	-	-	5,8	-	-	5,2	-	8,7	-	-
84	-	-	-	-	-	-	-	-	-	-	4,7	-	8,1	-	-
86	-	-	-	-	-	-	-	-	-	-	4,2	-	-	-	-
88	-	-	-	-	-	-	-	-	-	-	-	-	-	-	-

### Remarks · Bemerkungen · Remarques

Main boom angle 85°, 75° and 65°, capacities for intermediate boom positions are calculated by the crane control system IC-1  
 Hauptauslegerwinkel 85°, 75° und 65°, Traglasten für Zwischenstellungen des Hauptauslegers werden von der Kransteuerung IC-1 berechnet  
 Jarret de flèche principale 85°, 75° et 65°, le système de commande de la grue IC-1 calcule les charges pour les positions intermédiaires de la flèche



**SW LIFTING CAPACITIES · TRAGFÄHIGKEITEN ·**  
**CAPACITÉS DE LEVAGE**

180 t + 60 t ZB 8,40 m 360° DIN/ISO

54 m

m	24 m			30 m			36 m			42 m			48 m			54 m		
	85°	75°	65°	85°	75°	65°	85°	75°	65°	85°	75°	65°	85°	75°	65°	85°	75°	65°
16	t	t	t	t	t	t	t	t	t	t	t	t	t	t	t	t	t	t
18	166,0	-	-	-	-	-	-	-	-	-	-	-	-	-	-	-	-	-
20	141,0	-	-	140,0	-	-	-	-	-	-	-	-	-	-	-	-	-	-
22	122,0	-	-	121,0	-	-	120,0	-	-	-	-	-	-	-	-	-	-	-
24	107,0	-	-	106,0	-	-	105,0	-	-	104,0	-	-	-	-	-	-	-	-
26	95,5	-	-	94,5	-	-	93,5	-	-	92,5	-	-	91,5	-	-	-	-	-
28	85,5	-	-	85,0	-	-	84,0	-	-	83,0	-	-	82,0	-	-	81,0	-	-
30	77,5	-	-	77,0	-	-	76,0	-	-	75,0	-	-	74,0	-	-	73,0	-	-
32	71,0	60,5	-	70,0	-	-	69,5	-	-	68,0	-	-	67,5	-	-	66,5	-	-
34	-	55,5	-	64,7	54,0	-	64,0	-	-	62,7	-	-	62,0	-	-	61,0	-	-
36	-	51,0	-	59,5	49,9	-	58,5	-	-	57,5	-	-	56,5	-	-	55,5	-	-
38	-	47,3	-	-	46,2	-	54,5	44,9	-	53,5	-	-	52,6	-	-	51,5	-	-
40	-	44,0	-	-	42,9	-	50,5	41,7	-	49,5	40,5	-	48,8	-	-	47,6	-	-
42	-	41,0	-	-	39,9	-	47,3	38,7	-	46,2	37,6	-	45,5	-	-	44,4	-	-
44	-	-	31,0	-	37,3	-	44,1	36,2	-	43,0	35,0	-	42,3	34,0	-	41,2	-	-
46	-	-	28,9	-	34,9	-	-	33,8	-	40,4	32,7	-	39,7	31,6	-	38,6	30,0	-
50	-	-	27,0	-	-	25,5	-	31,7	-	37,9	30,5	-	37,2	29,4	-	36,0	27,8	-
54	-	-	-	-	-	22,3	-	28,1	20,6	-	26,7	-	32,9	25,6	-	31,8	24,1	-
56	-	-	-	-	-	19,7	-	-	18,1	-	23,6	16,6	-	22,5	-	28,2	20,9	-
58	-	-	-	-	-	-	-	-	16,9	-	22,2	15,5	-	21,1	-	26,7	19,6	-
62	-	-	-	-	-	-	-	-	15,9	-	-	14,5	-	19,8	13,3	25,3	18,3	-
66	-	-	-	-	-	-	-	-	-	-	-	12,6	-	17,6	11,4	-	16,1	9,8
68	-	-	-	-	-	-	-	-	-	-	-	11,1	-	-	9,9	-	14,2	8,2
70	-	-	-	-	-	-	-	-	-	-	-	-	-	-	9,2	-	13,3	7,5
74	-	-	-	-	-	-	-	-	-	-	-	-	-	-	8,5	-	-	6,9
74	-	-	-	-	-	-	-	-	-	-	-	-	-	-	-	-	-	5,7

m	60 m			66 m			72 m			78 m			84 m		
	85°	75°	65°	85°	75°	65°	85°	75°	65°	85°	75°	65°	85°	75°	65°
28	t	t	t	t	t	t	t	t	t	t	t	t	t	t	t
30	72,5	-	-	-	-	-	-	-	-	-	-	-	-	-	-
34	65,5	-	-	65,0	-	-	-	-	-	-	-	-	-	-	-
38	55,0	-	-	54,0	-	-	53,0	-	-	52,5	-	-	-	-	-
42	46,9	-	-	46,2	-	-	45,0	-	-	44,8	-	-	43,8	-	-
46	40,5	-	-	39,8	-	-	38,6	-	-	38,4	-	-	37,4	-	-
50	35,3	26,8	-	34,6	-	-	33,4	-	-	33,2	-	-	32,2	-	-
54	31,1	23,1	-	30,4	22,0	-	29,2	-	-	28,9	-	-	27,9	-	-
58	29,3	21,4	-	28,6	20,4	-	27,3	18,8	-	27,0	-	-	26,0	-	-
62	27,5	20,0	-	26,8	18,9	-	25,5	17,3	-	25,2	-	-	24,1	-	-
66	26,0	18,6	-	25,2	17,6	-	23,9	16,0	-	23,6	15,5	-	22,5	-	-
70	24,5	17,3	-	23,7	16,3	-	22,3	14,7	-	22,0	14,3	-	20,9	13,0	-
74	21,9	15,1	-	21,0	14,1	-	19,6	12,5	-	19,3	12,1	-	18,2	10,8	-
78	-	13,1	7,1	18,7	12,1	-	17,2	10,6	-	16,9	10,1	-	15,8	8,9	-
82	-	11,5	5,7	16,7	10,4	-	15,2	8,9	-	14,8	8,4	-	13,7	7,2	-
86	-	10,0	4,6	-	9,0	-	13,5	7,4	-	13,0	7,0	-	11,9	5,7	-
80	-	-	4,0	-	8,3	-	-	6,8	-	12,2	6,3	-	11,1	5,0	-
84	-	-	-	-	7,8	-	-	6,2	-	11,4	5,7	-	10,3	4,4	-
88	-	-	-	-	7,2	-	-	5,6	-	10,7	5,1	-	9,6	-	-
92	-	-	-	-	-	-	-	5,1	-	10,1	4,5	-	8,9	-	-
96	-	-	-	-	-	-	-	4,6	-	-	4,0	-	8,3	-	-
100	-	-	-	-	-	-	-	4,1	-	-	-	-	7,7	-	-

**Remarks · Bemerkungen · Remarques**

Main boom angle 85°, 75° and 65°, capacities for intermediate boom positions are calculated by the crane control system IC-1  
 Hauptauslegerwinkel 85°, 75° und 65°, Traglasten für Zwischenstellungen des Hauptauslegers werden von der Kransteuerung IC-1 berechnet  
 Jarret de flèche principale 85°, 75° et 65°, le système de commande de la grue IC-1 calcule les charges pour les positions intermédiaires de la flèche

# SW LIFTING CAPACITIES · TRAGFÄHIGKEITEN · CAPACITÉS DE LEVAGE

180 t + 60 t ZB      8,40 m      360°      DIN/ISO

60 m

m	24 m			30 m			36 m			42 m			48 m			54 m		
	85°	75°	65°	85°	75°	65°	85°	75°	65°	85°	75°	65°	85°	75°	65°	85°	75°	65°
18	t	t	t	t	t	t	t	t	t	t	t	t	t	t	t	t	t	t
20	139,0	-	-	-	-	-	-	-	-	-	-	-	-	-	-	-	-	-
22	120,0	-	-	119,0	-	-	118,0	-	-	-	-	-	-	-	-	-	-	-
24	106,0	-	-	105,0	-	-	104,0	-	-	103,0	-	-	-	-	-	-	-	-
26	94,5	-	-	93,5	-	-	92,5	-	-	91,5	-	-	90,5	-	-	-	-	-
28	84,5	-	-	84,0	-	-	83,0	-	-	82,0	-	-	81,0	-	-	80,0	-	-
30	76,5	-	-	76,0	-	-	75,0	-	-	74,0	-	-	73,0	-	-	72,0	-	-
32	70,0	-	-	69,0	-	-	68,5	-	-	67,5	-	-	66,5	-	-	65,5	-	-
34	-	53,0	-	63,7	-	-	63,2	-	-	62,0	-	-	61,2	-	-	60,0	-	-
36	-	48,8	-	58,5	47,6	-	58,0	-	-	56,5	-	-	56,0	-	-	54,5	-	-
38	-	41,9	-	-	40,7	-	49,8	39,5	-	48,7	-	-	48,0	-	-	46,9	-	-
40	-	39,0	-	-	37,9	-	46,6	36,7	-	45,5	35,3	-	44,8	-	-	43,7	-	-
42	-	-	-	-	35,4	-	43,5	34,1	-	42,4	32,8	-	41,7	31,6	-	40,5	-	-
44	-	-	-	-	31,1	-	-	29,7	-	37,3	28,3	-	36,5	27,3	-	35,4	25,6	-
46	-	-	23,8	-	-	-	-	-	-	-	-	-	-	-	-	-	-	-
48	-	-	20,8	-	-	19,2	-	26,1	-	-	24,7	-	32,3	23,7	-	31,2	22,1	-
50	-	-	-	-	-	17,9	-	24,5	-	-	23,2	-	30,6	22,1	-	29,4	20,5	-
52	-	-	-	-	-	16,8	-	-	15,1	-	21,7	-	28,9	20,6	-	27,7	19,1	-
54	-	-	-	-	-	-	-	-	13,2	-	19,2	11,7	-	18,1	-	24,7	16,6	-
56	-	-	-	-	-	-	-	-	11,5	-	-	10,1	-	16,0	8,8	-	14,4	-
58	-	-	-	-	-	-	-	-	-	-	-	9,3	-	15,1	8,1	-	13,5	-
60	-	-	-	-	-	-	-	-	-	-	-	8,7	-	-	7,4	-	12,6	5,7
62	-	-	-	-	-	-	-	-	-	-	-	-	-	-	6,2	-	11,1	4,5
64	-	-	-	-	-	-	-	-	-	-	-	-	-	-	5,2	-	-	-
66	-	-	-	-	-	-	-	-	-	-	-	-	-	-	-	-	-	-
68	-	-	-	-	-	-	-	-	-	-	-	-	-	-	-	-	-	-
70	-	-	-	-	-	-	-	-	-	-	-	-	-	-	-	-	-	-
72	-	-	-	-	-	-	-	-	-	-	-	-	-	-	-	-	-	-
74	-	-	-	-	-	-	-	-	-	-	-	-	-	-	-	-	-	-
76	-	-	-	-	-	-	-	-	-	-	-	-	-	-	-	-	-	-
78	-	-	-	-	-	-	-	-	-	-	-	-	-	-	-	-	-	-

m	60 m			66 m			72 m			78 m			84 m		
	85°	75°	65°	85°	75°	65°	85°	75°	65°	85°	75°	65°	85°	75°	65°
28	t	t	t	t	t	t	t	t	t	t	t	t	t	t	t
30	71,5	-	-	-	-	-	-	-	-	-	-	-	-	-	-
32	64,5	-	-	64,0	-	-	-	-	-	-	-	-	-	-	-
34	54,0	-	-	53,5	-	-	52,0	-	-	50,0	-	-	-	-	-
36	46,2	-	-	45,5	-	-	44,2	-	-	44,0	-	-	43,0	-	-
38	39,8	-	-	39,1	-	-	37,9	-	-	37,7	-	-	36,7	-	-
40	34,7	-	-	34,0	-	-	32,8	-	-	32,6	-	-	31,6	-	-
42	32,6	22,7	-	31,9	-	-	30,7	-	-	30,4	-	-	29,4	-	-
44	30,5	21,1	-	29,8	-	-	28,6	-	-	28,3	-	-	27,2	-	-
46	28,7	19,5	-	28,0	18,4	-	26,7	-	-	26,4	-	-	25,3	-	-
48	27,0	18,1	-	26,2	17,0	-	24,9	15,4	-	24,6	-	-	23,5	-	-
50	25,5	16,8	-	24,6	15,7	-	23,3	14,1	-	23,0	13,7	-	21,9	-	-
52	24,0	15,6	-	23,1	14,5	-	21,7	12,9	-	21,4	12,5	-	20,3	-	-
54	22,6	14,4	-	21,7	13,4	-	20,3	11,8	-	20,0	11,4	-	18,9	10,1	-
56	21,3	13,4	-	20,4	12,4	-	19,0	10,8	-	18,7	10,4	-	17,6	9,1	-
58	-	11,6	-	18,1	10,5	-	16,7	9,0	-	16,4	8,5	-	15,2	7,2	-
60	-	10,0	-	16,1	9,0	-	14,7	7,4	-	14,3	6,9	-	13,2	5,6	-
62	-	8,6	-	-	7,6	-	12,9	6,0	-	12,5	5,5	-	11,4	4,3	-
64	-	8,0	-	-	6,9	-	-	5,4	-	11,7	4,9	-	10,6	-	-
66	-	-	-	-	6,4	-	-	4,8	-	11,0	4,3	-	9,8	-	-
68	-	-	-	-	5,8	-	-	4,2	-	10,3	-	-	9,1	-	-
70	-	-	-	-	5,4	-	-	-	-	9,6	-	-	8,4	-	-
72	-	-	-	-	-	-	-	-	-	-	-	-	7,2	-	-
74	-	-	-	-	-	-	-	-	-	-	-	-	-	-	-
76	-	-	-	-	-	-	-	-	-	-	-	-	-	-	-
78	-	-	-	-	-	-	-	-	-	-	-	-	-	-	-
80	-	-	-	-	-	-	-	-	-	-	-	-	-	-	-
82	-	-	-	-	-	-	-	-	-	-	-	-	-	-	-
84	-	-	-	-	-	-	-	-	-	-	-	-	-	-	-
86	-	-	-	-	-	-	-	-	-	-	-	-	-	-	-
88	-	-	-	-	-	-	-	-	-	-	-	-	-	-	-
90	-	-	-	-	-	-	-	-	-	-	-	-	-	-	-

### Remarks · Bemerkungen · Remarques

Main boom angle 85°, 75° and 65°, capacities for intermediate boom positions are calculated by the crane control system IC-1  
 Hauptauslegerwinkel 85°, 75° und 65°, Traglasten für Zwischenstellungen des Hauptauslegers werden von der Kransteuerung IC-1 berechnet  
 Jarret de flèche principale 85°, 75° et 65°, le système de commande de la grue IC-1 calcule les charges pour les positions intermédiaires de la flèche

**SW LIFTING CAPACITIES · TRAGFÄHIGKEITEN · CAPACITÉS DE LEVAGE**

180 t + 60 t ZB 8,40 m 360° DIN/ISO

66 m

m	24 m			30 m			36 m			42 m			48 m			54 m		
	85°	75°	65°	85°	75°	65°	85°	75°	65°	85°	75°	65°	85°	75°	65°	85°	75°	65°
18	t	t	t	t	t	t	t	t	t	t	t	t	t	t	t	t	t	t
20	136,0	-	-	-	-	-	-	-	-	-	-	-	-	-	-	-	-	-
22	119,0	-	-	118,0	-	-	-	-	-	-	-	-	-	-	-	-	-	-
24	105,0	-	-	104,0	-	-	103,0	-	-	-	-	-	-	-	-	-	-	-
26	93,0	-	-	92,0	-	-	91,5	-	-	90,0	-	-	-	-	-	-	-	-
28	83,5	-	-	83,0	-	-	82,0	-	-	81,0	-	-	-	-	80,0	-	-	-
30	76,0	-	-	75,0	-	-	74,0	-	-	73,0	-	-	-	-	72,0	-	-	71,0
32	69,0	-	-	68,5	-	-	67,5	-	-	66,5	-	-	-	-	65,5	-	-	64,5
34	-	50,5	-	63,0	-	-	62,2	-	-	61,2	-	-	-	-	60,2	-	-	59,2
36	-	46,5	-	57,5	-	-	57,0	-	-	56,0	-	-	-	-	55,0	-	-	54,0
38	-	43,0	-	-	41,7	-	53,0	-	-	52,0	-	-	-	-	51,1	-	-	50,0
42	-	39,9	-	-	38,7	-	49,1	37,1	-	48,0	-	-	-	-	47,3	-	-	46,1
44	-	34,7	-	-	33,3	-	42,8	31,9	-	41,7	30,5	-	-	-	41,0	-	-	39,8
46	-	-	-	-	31,1	-	-	29,7	-	39,1	28,3	-	-	-	38,4	27,1	-	37,2
48	-	-	-	-	29,0	-	-	27,6	-	36,6	26,3	-	-	-	35,9	25,2	-	34,7
50	-	-	17,9	-	27,2	-	-	25,8	-	-	24,4	-	-	-	33,8	23,4	-	32,6
54	-	-	15,6	-	-	16,2	-	24,2	-	-	22,8	-	-	-	31,8	21,7	-	30,6
58	-	-	-	-	-	14,0	-	21,3	12,3	-	19,9	-	-	-	28,3	18,9	-	27,1
60	-	-	-	-	-	12,2	-	-	10,5	-	17,5	9,1	-	-	16,4	-	-	24,2
62	-	-	-	-	-	-	-	-	9,7	-	16,5	8,3	-	-	15,4	-	-	24,2
66	-	-	-	-	-	-	-	-	9,0	-	-	7,6	-	-	14,4	6,3	-	12,8
68	-	-	-	-	-	-	-	-	-	-	-	6,3	-	-	12,7	5,0	-	11,1
70	-	-	-	-	-	-	-	-	-	-	-	5,7	-	-	4,5	-	-	10,3
72	-	-	-	-	-	-	-	-	-	-	-	5,2	-	-	-	-	-	9,6
74	-	-	-	-	-	-	-	-	-	-	-	-	-	-	-	-	-	9,0

m	60 m			66 m			72 m			78 m			84 m		
	85°	75°	65°	85°	75°	65°	85°	75°	65°	85°	75°	65°	85°	75°	65°
28	t	t	t	t	t	t	t	t	t	t	t	t	t	t	t
30	66,0	-	-	-	-	-	-	-	-	-	-	-	-	-	-
34	63,5	-	-	58,0	-	-	-	-	-	-	-	-	-	-	-
38	53,0	-	-	52,5	-	-	51,0	-	-	44,0	-	-	-	-	-
42	45,5	-	-	44,7	-	-	43,5	-	-	43,2	-	-	39,0	-	-
46	39,2	-	-	38,4	-	-	37,2	-	-	37,0	-	-	36,0	-	-
50	34,1	-	-	33,3	-	-	32,1	-	-	31,9	-	-	30,9	-	-
54	29,9	19,1	-	29,2	-	-	27,9	-	-	27,6	-	-	26,5	-	-
58	28,1	17,6	-	27,4	16,5	-	26,0	-	-	25,7	-	-	24,6	-	-
62	26,4	16,2	-	25,6	15,2	-	24,2	-	-	23,9	-	-	22,8	-	-
66	24,9	15,0	-	24,0	13,9	-	22,6	12,3	-	22,3	-	-	21,2	-	-
70	23,4	13,8	-	22,5	12,8	-	21,1	11,1	-	20,8	10,7	-	19,7	-	-
74	20,7	11,8	-	19,8	10,8	-	18,4	9,1	-	18,1	8,7	-	17,0	7,4	-
78	18,5	10,0	-	17,5	9,0	-	16,1	7,4	-	15,8	7,0	-	14,7	5,6	-
82	-	8,5	-	15,6	7,5	-	14,1	5,9	-	13,8	5,4	-	12,6	4,1	-
86	-	7,2	-	-	6,2	-	12,4	4,6	-	12,0	4,1	-	10,9	-	-
	-	6,6	-	-	5,6	-	11,6	-	-	11,2	-	-	10,1	-	-
	-	-	-	-	5,0	-	10,9	-	-	10,5	-	-	9,3	-	-
	-	-	-	-	4,1	-	-	-	-	9,1	-	-	7,9	-	-
	-	-	-	-	-	-	-	-	-	-	-	-	6,7	-	-

**Remarks · Bemerkungen · Remarques**

Main boom angle 85°, 75° and 65°, capacities for intermediate boom positions are calculated by the crane control system IC-1  
 Hauptauslegerwinkel 85°, 75° und 65°, Traglasten für Zwischenstellungen des Hauptauslegers werden von der Kransteuerung IC-1 berechnet  
 Jarret de flèche principale 85°, 75° et 65°, le système de commande de la grue IC-1 calcule les charges pour les positions intermédiaires de la flèche

**SWSL WORKING RANGES · ARBEITSBEREICHE · PORTÉES**

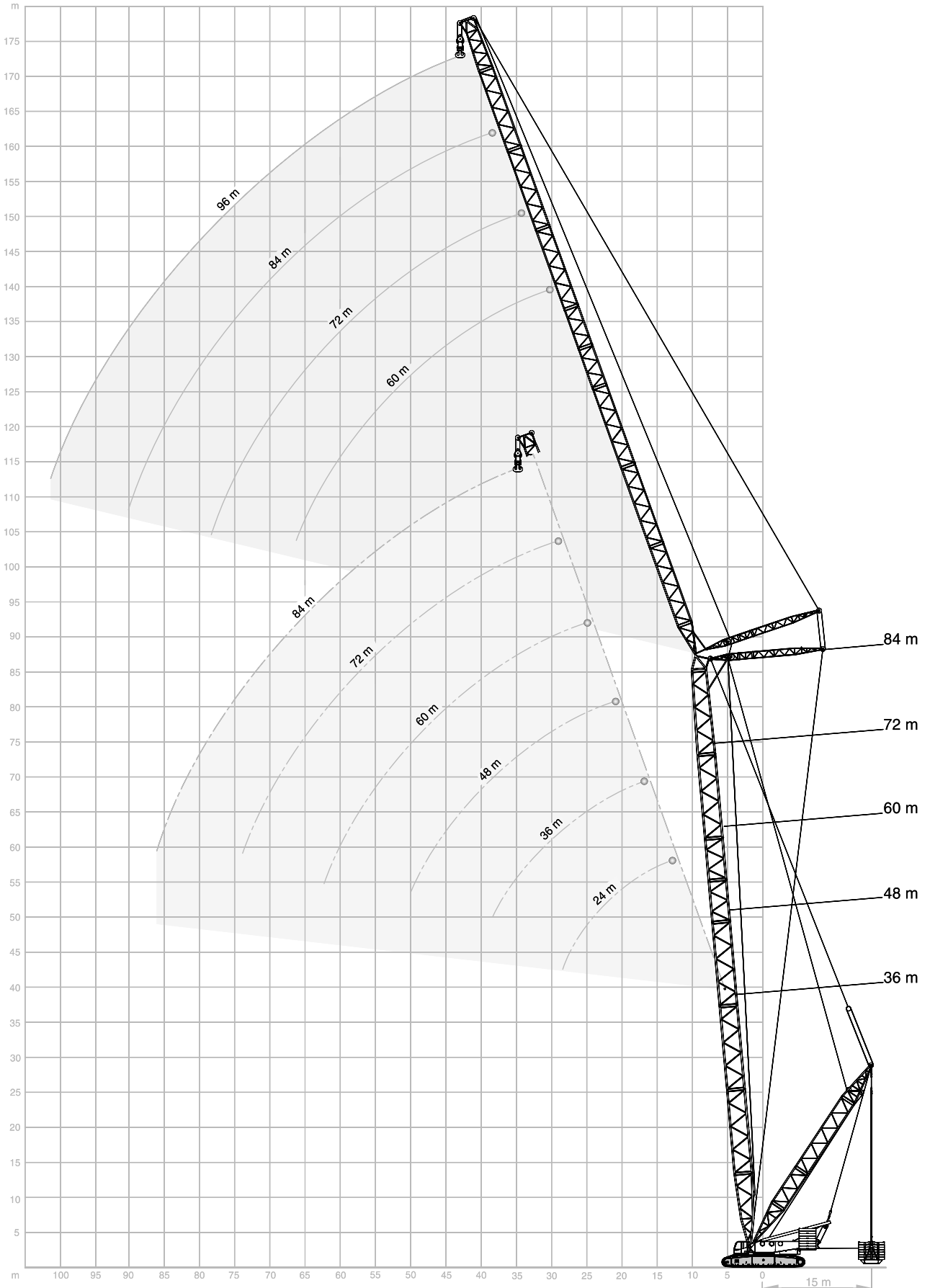

**SWSL / SFSL 15° / HSWSL** LIFTING CAPACITIES · TRAGFÄHIGKEITEN · CAPACITÉS DE LEVAGE

8,4 m 11-15 m 360° DIN/ISO

36 m + 24 m

m	SWSL						SFSL	HSWSL
	0 t-250 t						160 t	85°
	0 t	180 t+ 60 t ZB						
85°	85°	75°	65°	55°	85°	t	t	
16	183,0	300,0	-	-	-	300,0	-	
18	155,0	300,0	-	-	-	300,0	-	
20	135,0	300,0	-	-	-	300,0	-	
22	118,0	288,0	-	-	-	283,0	-	
24	105,0	248,0	-	-	-	263,0	-	
26	95,0	214,0	243,0	-	-	246,0	-	
28	86,0	182,0	228,0	-	-	231,0	-	
30	-	-	214,0	-	-	217,0	-	
34	-	-	191,0	175,0	-	185,0	-	
38	-	-	-	162,0	-	160,0	-	
40	-	-	-	153,0	-	150,5	-	
42	-	-	-	-	135,0	141,0	-	
46	-	-	-	-	127,0	123,0	-	
50	-	-	-	-	-	104,0	-	
54	-	-	-	-	-	90,0	-	

36 m + 36 m

m	t	t	t	t	t	t	t
18	154,0	257,0	-	-	-	-	-
20	133,0	257,0	-	-	-	253,0	-
22	117,0	253,0	-	-	-	249,0	-
24	104,0	239,0	-	-	-	245,0	-
26	93,5	226,0	-	-	-	239,0	-
28	85,0	208,0	-	-	-	224,0	-
30	77,5	187,0	199,0	-	-	208,0	-
34	65,5	152,0	183,0	-	-	185,0	-
38	56,5	123,0	165,0	-	-	161,0	-
42	-	-	146,0	141,0	-	142,0	-
46	-	-	118,0	128,0	-	126,0	-
50	-	-	-	116,0	-	112,0	-
52	-	-	-	111,0	107,0	106,5	-
54	-	-	-	-	102,0	101,0	-
58	-	-	-	-	94,5	87,0	-
62	-	-	-	-	-	76,0	-
66	-	-	-	-	-	66,0	-

36 m + 48 m

m	t	t	t	t	t	t	t
22	115,0	187,0	-	-	-	-	-
24	102,0	187,0	-	-	-	186,0	-
26	92,0	187,0	-	-	-	185,0	-
28	83,0	180,0	-	-	-	183,0	-
30	75,5	172,0	-	-	-	181,0	-
34	64,0	156,0	-	-	-	164,0	-
36	59,5	146,0	153,0	-	-	156,5	-
38	55,0	136,0	153,0	-	-	149,0	-
42	48,0	116,0	135,0	-	-	138,0	-
46	42,4	99,5	120,0	-	-	126,0	-
50	37,7	84,0	109,0	112,0	-	113,0	-
54	-	-	97,5	104,0	-	102,0	-
58	-	-	82,0	95,5	-	92,0	-
60	-	-	-	91,5	86,5	88,0	-
62	-	-	-	88,0	85,0	84,0	-
64	-	-	-	84,5	82,0	79,0	-
66	-	-	-	-	79,0	74,0	-
68	-	-	-	-	76,0	69,0	-
70	-	-	-	-	-	64,0	-
74	-	-	-	-	-	58,0	-
78	-	-	-	-	-	49,0	-

36 m + 60 m

m	SWSL						SFSL	HSWSL
	0 t-250 t						160 t	85°
	0 t	180 t+ 60 t ZB						
85°	85°	75°	65°	55°	85°	t	t	
26	90,0	134,0	-	-	-	-	-	
28	81,5	134,0	-	-	-	134,0	-	
30	74,0	134,0	-	-	-	133,0	-	
34	62,0	128,0	-	-	-	133,0	-	
38	53,0	119,0	-	-	-	130,0	-	
42	46,3	110,0	117,0	-	-	124,0	-	
46	40,6	100,0	112,0	-	-	116,0	-	
50	35,9	90,0	102,0	-	-	105,0	-	
54	32,0	78,5	96,0	-	-	94,0	-	
56	30,3	73,5	93,0	86,5	-	90,0	-	
58	28,7	68,5	88,5	86,5	-	86,0	-	
62	25,9	58,5	78,0	80,0	-	81,0	-	
66	-	-	68,0	73,5	-	76,0	-	
70	-	-	58,0	68,5	68,5	70,0	-	
74	-	-	-	63,5	65,5	62,0	-	
76	-	-	-	61,0	63,0	58,5	-	
78	-	-	-	-	61,0	55,0	-	
80	-	-	-	-	58,5	52,0	-	
82	-	-	-	-	-	50,0	-	
86	-	-	-	-	-	43,0	-	
90	-	-	-	-	-	37,0	-	

36 m + 72 m

m	t	t	t	t	t	t	t
30	72,0	96,0	-	-	-	-	-
34	60,5	96,0	-	-	-	95,0	-
38	51,5	94,0	-	-	-	94,0	-
42	44,4	91,0	-	-	-	93,0	-
46	38,7	87,0	-	-	-	91,0	-
48	36,3	85,0	87,0	-	-	89,5	-
50	34,0	83,0	86,0	-	-	88,0	-
54	30,1	79,0	84,0	-	-	83,0	-
58	26,8	72,0	81,0	-	-	78,0	-
62	23,9	64,0	78,0	-	-	73,0	-
64	22,6	60,2	75,5	67,0	-	70,5	-
66	21,3	56,5	71,5	66,5	-	68,0	-
70	19,1	49,8	64,0	64,0	-	64,0	-
74	17,2	42,8	57,0	60,5	-	61,0	-
78	-	-	50,0	57,5	57,5	57,0	-
80	-	-	46,8	56,0	55,5	54,5	-
82	-	-	-	54,0	54,0	52,0	-
86	-	-	-	49,8	50,0	46,0	-
90	-	-	-	-	47,1	42,0	-
92	-	-	-	-	45,6	39,5	-
94	-	-	-	-	-	37,0	-
98	-	-	-	-	-	32,0	-
102	-	-	-	-	-	28,0	-

**Remarks · Bemerkungen · Remarques**

Main boom angle 85°, 75° and 55°; capacities for intermediate boom positions are calculated by the crane control system IC-1

Hauptauslegerwinkel 85°, 75° und 55°; Traglasten für Zwischenstellungen des Hauptauslegers werden von der Kransteuerung IC-1 berechnet

Jarret de flèche principale 85°, 75° 65° et 55°; le système de commande de la grue IC-1 calcule les charges pour les positions intermédiaires de la flèche

For HSWSL a boom power-kit is required · Für HSWSL ist ein Ausleger-Verstärkungs-Kit erforderlich · Un kit à fortifier de flèche principale est nécessaire pour HSWSL

# SWSL / SFSL 15° / HSWSL LIFTING CAPACITIES · TRAGFÄHIGKEITEN · CAPACITÉS DE LEVAGE

8,4 m
11-15 m
360°
DIN/ISO

**36 m + 84 m**

		SWSL				SFSL	HSWSL
		0 t-250 t					
		160 t					
		180 t+ 60 t ZB					
		85°	85°	75°	65°	55°	85°
m	t	t	t	t	t	t	t
34	59,0	69,0	-	-	-	-	-
38	50,0	69,0	-	-	-	69,0	-
42	43,3	68,0	-	-	-	68,0	-
46	37,6	68,0	-	-	-	68,0	-
50	32,9	67,0	-	-	-	67,0	-
54	28,9	66,0	63,0	-	-	66,0	-
58	25,5	65,0	63,0	-	-	64,0	-
62	22,5	63,0	62,0	-	-	62,0	-
66	19,9	59,0	61,0	-	-	60,0	-
70	17,6	53,0	60,0	-	-	57,0	-
72	16,5	50,2	59,0	50,0	-	56,0	-
74	15,5	47,4	58,5	50,0	-	55,0	-
78	13,8	42,2	53,0	49,9	-	52,0	-
82	12,2	37,2	47,8	48,4	-	50,0	-
86	10,9	31,9	42,8	46,7	-	46,0	-
88	-	-	40,3	45,8	44,1	44,5	-
90	-	-	37,9	44,7	44,1	43,0	-
92	-	-	35,3	43,6	43,7	41,0	-
94	-	-	-	42,5	42,3	39,0	-
98	-	-	-	37,9	39,5	36,0	-
102	-	-	-	-	37,1	32,0	-
104	-	-	-	-	35,9	29,5	-
106	-	-	-	-	-	27,0	-
110	-	-	-	-	-	24,0	-
114	-	-	-	-	-	21,0	-

**48 m + 24 m**

m	t	t	t	t	t	t	t
16	181,0	297,0	-	-	-	298,0	-
18	153,0	297,0	-	-	-	298,0	-
20	133,0	293,0	-	-	-	297,0	-
22	116,0	280,0	-	-	-	296,0	-
24	104,0	265,0	-	-	-	282,0	-
26	93,5	229,0	-	-	-	260,0	-
28	85,0	196,0	231,0	-	-	236,0	-
30	77,5	162,0	218,0	-	-	215,0	-
34	-	-	187,0	-	-	182,0	-
38	-	-	164,0	-	-	157,0	-
40	-	-	-	148,0	-	147,5	-
42	-	-	-	140,0	-	138,0	-
46	-	-	-	126,0	-	122,0	-
50	-	-	-	-	-	109,0	-
54	-	-	-	-	-	98,0	-
58	-	-	-	-	-	88,0	-
62	-	-	-	-	-	77,0	-
66	-	-	-	-	-	66,0	-
70	-	-	-	-	-	-	-

**48 m + 36 m**

		SWSL				SFSL	HSWSL
		0 t-250 t					
		160 t					
		180 t+ 60 t ZB					
		85°	85°	75°	65°	55°	85°
m	t	t	t	t	t	t	t
20	131,0	223,0	-	-	-	-	-
22	115,0	219,0	-	-	-	221,0	-
24	102,0	212,0	-	-	-	219,0	-
26	92,0	203,0	-	-	-	218,0	-
28	83,5	194,0	-	-	-	216,0	-
30	76,0	185,0	-	-	-	206,0	-
34	64,5	159,0	183,0	-	-	184,0	-
38	55,5	129,0	162,0	-	-	159,0	-
42	-	-	144,0	-	-	139,0	-
46	-	-	129,0	-	-	123,0	-
48	-	-	123,0	117,0	-	116,0	-
50	-	-	109,0	111,0	-	109,0	-
54	-	-	-	102,0	-	98,0	-
56	-	-	-	97,5	-	93,5	-
58	-	-	-	-	89,5	89,0	-
62	-	-	-	-	82,5	81,0	-
64	-	-	-	-	79,5	77,5	-
66	-	-	-	-	-	74,0	-
70	-	-	-	-	-	67,0	-
74	-	-	-	-	-	57,0	-
78	-	-	-	-	-	51,0	-

**48 m + 48 m**

m	t	t	t	t	t	t	t
24	100,0	162,0	-	-	-	-	-
26	90,0	162,0	-	-	-	162,0	-
28	81,5	160,0	-	-	-	162,0	-
30	74,0	157,0	-	-	-	162,0	-
34	62,5	149,0	-	-	-	160,0	-
38	53,5	136,0	-	-	-	149,0	-
40	50,2	128,0	140,0	-	-	143,0	-
42	46,9	120,0	140,0	-	-	137,0	-
46	41,3	102,0	127,0	-	-	124,0	-
50	36,7	86,5	115,0	-	-	110,0	-
54	-	-	105,0	99,5	-	99,0	-
58	-	-	93,0	91,5	-	89,0	-
60	-	-	85,0	87,5	-	85,0	-
62	-	-	-	84,5	-	81,0	-
66	-	-	-	78,0	-	74,0	-
68	-	-	-	75,5	71,5	71,0	-
70	-	-	-	-	69,0	68,0	-
74	-	-	-	-	64,5	62,0	-
76	-	-	-	-	62,5	59,5	-
78	-	-	-	-	-	57,0	-
82	-	-	-	-	-	50,0	-
86	-	-	-	-	-	43,0	-
90	-	-	-	-	-	38,0	-

**Remarks · Bemerkungen · Remarques**

Main boom angle 85°, 75°, 65° and 55°; capacities for intermediate boom positions are calculated by the crane control system IC-1  
 Hauptauslegerwinkel 85°, 75°, 65° und 55°; Traglasten für Zwischenstellungen des Hauptauslegers werden von der Kransteuerung IC-1 berechnet  
 Jarret de flèche principale 85°, 75°, 65° et 55°; le système de commande de la grue IC-1 calcule les charges pour les positions intermédiaires de la flèche

For HSWSL a boom power-kit is required  
 Für HSWSL ist ein Ausleger-Verstärkungs-Kit erforderlich  
 Un kit à fortifier de flèche principale est nécessaire pour HSWSL

**SWSL / SFSL 15° / HSWSL LIFTING CAPACITIES · TRAGFÄHIGKEITEN · CAPACITÉS DE LEVAGE**

8,4 m 11-15 m 360° DIN/ISO

48 m + 60 m

m	SWSL						SFSL	HSWSL
	0 t-250 t						160 t	85°
	0 t	180 t+ 60 t ZB						
	85°	85°	75°	65°	55°			
	t	t	t	t	t	t	t	
28	79,5	120,0	-	-	-	-	-	
30	72,5	120,0	-	-	-	120,0	-	
34	61,0	117,0	-	-	-	120,0	-	
38	52,0	112,0	-	-	-	120,0	-	
42	45,1	106,0	-	-	-	117,0	-	
46	39,5	98,0	110,0	-	-	114,0	-	
50	34,9	91,0	105,0	-	-	107,0	-	
54	31,0	80,5	95,0	-	-	98,0	-	
58	27,8	70,0	87,0	-	-	90,0	-	
62	25,0	60,0	80,0	81,5	-	81,0	-	
66	-	-	74,0	76,0	-	74,0	-	
70	-	-	65,0	70,5	-	68,0	-	
72	-	-	60,0	68,0	-	65,0	-	
74	-	-	-	65,5	-	62,0	-	
76	-	-	-	63,5	60,0	59,5	-	
78	-	-	-	61,5	58,0	57,0	-	
80	-	-	-	59,5	56,0	55,0	-	
82	-	-	-	-	54,5	53,0	-	
86	-	-	-	-	51,0	49,0	-	
88	-	-	-	-	49,9	46,0	-	
90	-	-	-	-	-	43,0	-	
94	-	-	-	-	-	37,0	-	
98	-	-	-	-	-	33,0	-	
102	-	-	-	-	-	28,0	-	
106	-	-	-	-	-	-	-	

48 m + 72 m

m	t	t	t	t	t	t	t
34	59,0	87,0	-	-	-	87,0	-
38	50,0	86,0	-	-	-	86,0	-
42	43,3	83,0	-	-	-	86,0	-
46	37,7	80,0	-	-	-	85,0	-
50	33,0	77,0	79,0	-	-	83,0	-
54	29,2	74,0	79,0	-	-	81,0	-
58	25,9	71,0	78,0	-	-	77,0	-
62	22,9	65,0	77,0	-	-	73,0	-
66	20,4	57,5	72,0	-	-	68,0	-
70	18,2	50,5	67,0	62,0	-	63,0	-
74	16,2	43,6	61,5	61,5	-	61,0	-
78	-	-	54,5	59,0	-	57,0	-
82	-	-	47,8	55,5	-	52,0	-
84	-	-	44,2	53,5	-	50,0	-
86	-	-	-	52,0	48,9	48,0	-
90	-	-	-	49,2	46,0	45,0	-
92	-	-	-	47,4	44,6	43,0	-
94	-	-	-	-	43,4	41,0	-
98	-	-	-	-	41,0	36,0	-
100	-	-	-	-	40,0	33,5	-
102	-	-	-	-	-	31,0	-
106	-	-	-	-	-	27,0	-
110	-	-	-	-	-	24,0	-
114	-	-	-	-	-	20,0	-
118	-	-	-	-	-	-	-

48 m + 84 m

m	SWSL						SFSL	HSWSL
	0 t-250 t						160 t	85°
	0 t	180 t+ 60 t ZB						
	85°	85°	75°	65°	55°			
	t	t	t	t	t	t	t	
34	57,5	64,0	-	-	-	-	-	
38	49,0	64,0	-	-	-	64,0	-	
42	42,1	63,0	-	-	-	63,0	-	
46	36,5	62,0	-	-	-	63,0	-	
50	31,9	61,0	-	-	-	63,0	-	
54	28,0	60,0	-	-	-	62,0	-	
56	26,2	60,0	58,0	-	-	61,5	-	
58	24,5	60,0	58,0	-	-	61,0	-	
62	21,5	59,0	58,0	-	-	59,0	-	
66	18,9	58,0	58,0	-	-	57,0	-	
70	16,6	53,5	58,0	-	-	55,0	-	
74	14,7	48,0	58,0	-	-	53,0	-	
76	13,8	45,3	58,0	46,3	-	51,5	-	
78	12,9	42,7	56,5	46,3	-	50,0	-	
82	11,4	37,6	51,0	46,3	-	48,0	-	
86	10,1	32,4	45,9	45,9	-	44,0	-	
90	-	-	40,9	45,1	-	42,0	-	
94	-	-	35,9	43,9	40,4	40,0	-	
96	-	-	33,3	43,0	40,2	39,0	-	
98	-	-	-	42,0	39,0	38,0	-	
102	-	-	-	38,5	36,7	35,0	-	
104	-	-	-	36,0	35,7	33,0	-	
106	-	-	-	-	34,7	31,0	-	
110	-	-	-	-	32,8	27,0	-	
114	-	-	-	-	-	23,0	-	
118	-	-	-	-	-	21,0	-	
122	-	-	-	-	-	17,0	-	

60 m + 24 m

m	t	t	t	t	t	t	t
17	-	-	-	-	-	-	272,0
18	150,0	247,0	-	-	-	249,0	267,0
20	130,0	238,0	-	-	-	247,0	257,0
22	114,0	228,0	-	-	-	246,0	245,0
24	102,0	218,0	-	-	-	245,0	234,0
26	91,5	206,0	-	-	-	238,0	221,0
28	83,0	193,0	-	-	-	226,0	205,0
30	76,0	182,0	-	-	-	213,0	183,0
31	-	-	-	-	-	204,7	165,0
32	-	-	197,0	-	-	196,5	-
34	-	-	183,0	-	-	180,0	-
38	-	-	160,0	-	-	155,0	-
40	-	-	151,0	-	-	145,0	-
42	-	-	-	-	-	135,0	-
44	-	-	-	127,0	-	127,0	-
46	-	-	-	121,0	-	119,0	-
50	-	-	-	109,0	-	106,0	-
54	-	-	-	-	-	95,0	-
56	-	-	-	-	90,5	90,0	-
58	-	-	-	-	86,5	85,0	-
60	-	-	-	-	83,0	81,0	-
62	-	-	-	-	-	77,0	-
66	-	-	-	-	-	70,0	-
70	-	-	-	-	-	64,0	-
74	-	-	-	-	-	55,0	-
78	-	-	-	-	-	47,0	-
82	-	-	-	-	-	-	-

**Remarks · Bemerkungen · Remarques**  
see page 46 · siehe Seite 46 · voir page 46



# SWSL / SFSL 15° / HSWSL LIFTING CAPACITIES · TRAGFÄHIGKEITEN · CAPACITÉS DE LEVAGE

8,4 m 11-15 m

360°

DIN/ISO

60 m + 36 m

m	SWSL						SFSL	HSWSL
	0 t-250 t							
	160 t							
	85°	85°	75°	65°	55°		85°	
t	t	t	t	t	t	t	t	
20	128,0	181,0	-	-	-	-	196,0	
22	113,0	181,0	-	-	-	179,0	193,0	
24	100,0	176,0	-	-	-	178,0	188,0	
26	90,0	171,0	-	-	-	178,0	183,0	
28	81,5	165,0	-	-	-	178,0	177,0	
30	74,5	160,0	-	-	-	178,0	171,0	
34	63,0	149,0	-	-	-	170,0	159,0	
38	54,0	137,0	158,0	-	-	156,0	137,0	
42	47,5	109,0	140,0	-	-	136,0	109,0	
46	-	-	126,0	-	-	120,0	-	
50	-	-	114,0	-	-	107,0	-	
52	-	-	108,0	101,0	-	101,5	-	
54	-	-	-	97,0	-	96,0	-	
58	-	-	-	89,5	-	86,0	-	
62	-	-	-	82,5	-	78,0	-	
66	-	-	-	-	71,5	71,0	-	
70	-	-	-	-	66,5	64,0	-	
72	-	-	-	-	64,5	61,5	-	
74	-	-	-	-	-	59,0	-	
78	-	-	-	-	-	54,0	-	
82	-	-	-	-	-	48,0	-	
86	-	-	-	-	-	41,0	-	

60 m + 48 m

m	t	t	t	t	t	t	t
24	98,5	135,0	-	-	-	-	145,0
26	88,0	135,0	-	-	-	135,0	144,0
28	79,5	135,0	-	-	-	135,0	141,0
30	72,5	132,0	-	-	-	135,0	138,0
34	61,0	126,0	-	-	-	135,0	131,0
38	52,5	119,0	-	-	-	132,0	123,0
42	45,7	113,0	125,0	-	-	127,0	115,0
46	40,2	107,0	123,0	-	-	121,0	105,0
50	35,6	91,5	112,0	-	-	108,0	91,5
54	31,9	75,0	102,0	-	-	96,0	75,0
58	-	-	93,5	-	-	87,0	-
60	-	-	89,5	83,5	-	83,0	-
62	-	-	86,0	80,0	-	79,0	-
64	-	-	82,0	77,0	-	75,0	-
66	-	-	-	74,0	-	71,0	-
70	-	-	-	69,0	-	65,0	-
74	-	-	-	64,5	60,0	59,0	-
78	-	-	-	-	56,0	54,0	-
82	-	-	-	-	52,5	50,0	-
86	-	-	-	-	-	46,0	-
90	-	-	-	-	-	42,0	-
94	-	-	-	-	-	36,0	-
98	-	-	-	-	-	30,0	-

### Remarks · Bemerkungen · Remarques

Main boom angle 85°, 75°, 65° and 55°; capacities for intermediate boom positions are calculated by the crane control system IC-1  
 Hauptauslegerwinkel 85°, 75°, 65° und 55°; Traglasten für Zwischenstellungen des Hauptauslegers werden von der Kransteuerung IC-1 berechnet  
 Jarret de flèche principale 85°, 75°, 65° et 55°; le système de commande de la grue IC-1 calcule les charges pour les positions intermédiaires de la flèche

For HSWSL a boom power-kit is required · Für HSWSL ist ein Ausleger-Verstärkungs-Kit erforderlich · Un kit à fortifier de flèche principale est nécessaire pour HSWSL

60 m + 60 m

m	SWSL						SFSL	HSWSL
	0 t-250 t							
	160 t							
	85°	85°	75°	65°	55°		85°	
t	t	t	t	t	t	t	t	
28	78,0	102,0	-	-	-	-	109,0	
30	70,5	102,0	-	-	-	102,0	108,0	
34	59,0	101,0	-	-	-	102,0	104,0	
38	50,5	98,0	-	-	-	102,0	99,5	
42	43,9	95,0	-	-	-	101,0	93,0	
46	38,4	91,0	-	-	-	100,0	86,5	
48	36,1	88,5	96,0	-	-	100,0	83,2	
50	33,8	86,0	96,0	-	-	100,0	80,0	
54	30,0	82,0	94,0	-	-	93,0	75,0	
58	26,8	73,0	90,0	-	-	87,0	70,0	
62	24,1	63,0	84,0	-	-	79,0	63,0	
65	-	-	79,2	-	-	73,7	55,0	
66	-	-	77,5	72,0	-	72,0	-	
70	-	-	72,0	66,5	-	65,0	-	
74	-	-	63,0	62,0	-	60,0	-	
76	-	-	58,0	60,0	-	57,0	-	
78	-	-	-	58,0	-	54,0	-	
82	-	-	-	54,5	-	50,0	-	
84	-	-	-	53,0	48,6	48,0	-	
86	-	-	-	51,0	47,2	46,0	-	
90	-	-	-	-	44,4	42,0	-	
94	-	-	-	-	41,9	38,0	-	
98	-	-	-	-	-	35,0	-	
102	-	-	-	-	-	30,0	-	
106	-	-	-	-	-	26,0	-	
110	-	-	-	-	-	22,0	-	

60 m + 72 m

m	t	t	t	t	t	t	t
32	-	-	-	-	-	-	79,0
34	57,5	77,0	-	-	-	77,0	78,5
38	48,8	76,0	-	-	-	77,0	76,0
42	42,0	74,0	-	-	-	77,0	73,5
46	36,5	72,0	-	-	-	76,0	71,0
50	31,9	70,0	-	-	-	75,0	68,0
54	28,1	68,0	71,0	-	-	74,0	65,0
58	24,7	66,0	71,0	-	-	72,0	62,0
62	21,8	63,0	71,0	-	-	69,0	59,0
66	19,3	59,5	69,0	-	-	65,0	56,0
70	17,1	52,5	64,0	-	-	62,0	52,5
74	15,2	45,9	60,0	56,0	-	58,0	45,9
77	-	-	57,0	55,7	-	55,0	40,4
78	-	-	56,0	55,5	-	54,0	-
82	-	-	52,0	52,0	-	50,0	-
86	-	-	46,6	49,0	-	46,0	-
90	-	-	-	46,1	-	42,0	-
92	-	-	-	44,7	40,1	40,0	-
94	-	-	-	43,4	38,9	38,0	-
96	-	-	-	42,3	37,7	36,5	-
98	-	-	-	-	36,6	35,0	-
102	-	-	-	-	34,5	32,0	-
106	-	-	-	-	32,6	29,0	-
110	-	-	-	-	-	25,0	-
114	-	-	-	-	-	21,0	-
118	-	-	-	-	-	17,0	-
122	-	-	-	-	-	15,0	-



**SWSL / SFSL 15° / HSWSL** LIFTING CAPACITIES · TRAGFÄHIGKEITEN · CAPACITÉS DE LEVAGE

8,4 m 11-15 m 360° DIN/ISO

60 m + 84 m

m	SWSL						SFSL	HSWSL
	0 t-250 t						160 t	85°
	0 t	180 t+ 60 t ZB						
	85°	85°	75°	65°	55°	t	t	
35	-	-	-	-	-	-	58,0	
38	47,6	57,0	-	-	-	57,0	57,5	
42	40,8	57,0	-	-	-	57,0	56,5	
46	35,3	56,0	-	-	-	57,0	55,5	
50	30,7	55,0	-	-	-	57,0	54,5	
54	26,7	54,0	-	-	-	56,0	53,0	
58	23,3	53,0	-	-	-	55,0	52,0	
60	21,8	52,5	52,0	-	-	55,0	51,2	
62	20,4	52,0	52,0	-	-	55,0	50,5	
66	17,8	51,0	52,0	-	-	53,0	49,4	
70	15,6	49,0	52,0	-	-	51,0	47,4	
74	13,7	48,0	52,0	-	-	50,0	45,4	
78	12,0	44,0	52,0	-	-	48,0	43,4	
82	10,5	39,2	51,0	41,7	-	46,0	39,2	
86	9,2	34,2	48,0	41,7	-	44,0	34,2	
89	-	-	45,5	41,7	-	42,5	30,0	
90	-	-	45,0	41,7	-	42,0	-	
94	-	-	40,0	41,6	-	38,0	-	
98	-	-	35,1	39,1	-	35,0	-	
102	-	-	-	36,9	32,3	32,0	-	
106	-	-	-	34,8	30,4	29,0	-	
108	-	-	-	33,9	29,5	27,5	-	
110	-	-	-	-	28,6	26,0	-	
114	-	-	-	-	27,0	24,0	-	
118	-	-	-	-	25,6	21,0	-	
122	-	-	-	-	-	17,0	-	
126	-	-	-	-	-	14,0	-	
130	-	-	-	-	-	12,0	-	
134	-	-	-	-	-	9,0	-	

72 m + 36 m

m	SWSL						SFSL	HSWSL
	0 t-250 t						160 t	85°
	0 t	180 t+ 60 t ZB						
	85°	85°	75°	65°	55°	t	t	
22	110,0	139,0	-	-	-	-	163,0	
24	98,0	137,0	-	-	-	138,0	159,0	
26	88,0	134,0	-	-	-	138,0	154,0	
28	79,5	130,0	-	-	-	138,0	150,0	
30	72,5	126,0	-	-	-	138,0	145,0	
34	61,0	119,0	-	-	-	136,0	136,0	
38	52,5	112,0	-	-	-	132,0	127,0	
40	49,3	109,5	129,0	-	-	129,5	122,0	
42	46,1	107,0	129,0	-	-	127,0	117,0	
43	-	-	127,0	-	-	124,7	110,0	
46	-	-	122,0	-	-	118,0	-	
50	-	-	110,0	-	-	104,0	-	
54	-	-	101,0	-	-	93,0	-	
56	-	-	96,5	-	-	88,0	-	
58	-	-	-	84,5	-	83,0	-	
62	-	-	-	78,0	-	75,0	-	
66	-	-	-	72,0	-	68,0	-	
68	-	-	-	69,5	-	64,5	-	
70	-	-	-	-	-	61,0	-	
72	-	-	-	-	59,0	58,5	-	
74	-	-	-	-	57,0	56,0	-	
78	-	-	-	-	53,5	51,0	-	
82	-	-	-	-	-	46,0	-	
86	-	-	-	-	-	42,0	-	
90	-	-	-	-	-	38,0	-	
94	-	-	-	-	-	32,0	-	
98	-	-	-	-	-	27,0	-	

72 m + 24 m

m	t	t	t	t	t	t	t
18	147,0	185,0	-	-	-	-	217,0
20	127,0	185,0	-	-	-	186,0	214,0
22	112,0	175,0	-	-	-	184,0	205,0
24	99,5	168,0	-	-	-	184,0	197,0
26	89,5	162,0	-	-	-	184,0	188,0
28	81,0	157,0	-	-	-	182,0	181,0
30	74,0	152,0	-	-	-	176,0	173,0
32	-	-	-	-	-	173,0	165,0
34	-	-	168,0	-	-	170,0	-
38	-	-	156,0	-	-	152,0	-
42	-	-	138,0	-	-	132,0	-
44	-	-	131,0	-	-	124,0	-
46	-	-	-	-	-	116,0	-
50	-	-	-	104,0	-	103,0	-
54	-	-	-	95,0	-	92,0	-
56	-	-	-	91,0	-	87,0	-
58	-	-	-	-	-	82,0	-
62	-	-	-	-	-	74,0	-
66	-	-	-	-	-	67,0	-
70	-	-	-	-	-	61,0	-
74	-	-	-	-	-	55,0	-
78	-	-	-	-	-	50,0	-
82	-	-	-	-	-	44,0	-
86	-	-	-	-	-	38,0	-
90	-	-	-	-	-	-	-

72 m + 48 m

m	t	t	t	t	t	t	t
25	-	-	-	-	-	-	123,0
26	86,0	106,0	-	-	-	-	123,0
28	77,5	106,0	-	-	-	106,0	120,0
30	70,5	105,0	-	-	-	106,0	118,0
34	59,5	101,0	-	-	-	106,0	113,0
38	51,0	97,0	-	-	-	106,0	107,0
42	44,3	92,0	-	-	-	106,0	102,0
46	38,9	88,0	103,0	-	-	106,0	96,5
50	34,4	84,0	101,0	-	-	101,0	91,0
54	30,7	80,0	94,0	-	-	94,0	80,0
55	-	-	92,5	-	-	91,5	75,5
58	-	-	89,0	-	-	84,0	-
62	-	-	83,5	-	-	76,0	-
64	-	-	80,0	72,5	-	72,5	-
66	-	-	77,0	70,0	-	69,0	-
70	-	-	-	65,0	-	62,0	-
74	-	-	-	60,5	-	57,0	-
78	-	-	-	57,0	-	52,0	-
82	-	-	-	-	48,0	47,0	-
86	-	-	-	-	45,0	43,0	-
90	-	-	-	-	42,4	39,0	-
94	-	-	-	-	-	35,0	-
98	-	-	-	-	-	32,0	-
102	-	-	-	-	-	28,0	-
106	-	-	-	-	-	23,0	-
110	-	-	-	-	-	19,0	-
114	-	-	-	-	-	-	-

Remarks · Bemerkungen · Remarques: see page 48 · siehe Seite 48 · voir page 48

# SWSL / SFSL 15° / HSWSL LIFTING CAPACITIES · TRAGFÄHIGKEITEN · CAPACITÉS DE LEVAGE

8,4 m
11-15 m
360°
DIN/ISO

72 m + 60 m

		SWSL				SFSL	HSWSL
		0 t-250 t					
		160 t					
		85°	85°	75°	65°	55°	85°
m	t	t	t	t	t	t	t
29	-	-	-	-	-	-	93,5
30	68,5	82,0	-	-	-	-	93,5
34	57,5	81,0	-	-	-	82,0	90,5
38	49,2	79,0	-	-	-	82,0	87,5
42	42,5	76,0	-	-	-	82,0	84,0
46	37,1	73,0	-	-	-	82,0	80,0
50	32,6	71,0	-	-	-	82,0	76,5
52	30,7	70,0	79,0	-	-	81,5	74,5
54	28,9	69,0	79,0	-	-	81,0	72,5
58	25,7	66,0	79,0	-	-	77,0	67,5
62	22,9	64,0	77,0	-	-	72,0	63,5
66	20,4	55,5	74,0	-	-	68,0	55,5
67	-	-	73,0	-	-	66,7	52,5
70	-	-	69,5	-	-	63,0	-
72	-	-	67,0	60,5	-	60,0	-
74	-	-	65,0	58,0	-	57,0	-
78	-	-	60,5	54,5	-	52,0	-
82	-	-	-	51,0	-	47,0	-
86	-	-	-	47,9	-	43,0	-
90	-	-	-	45,2	39,3	39,0	-
94	-	-	-	-	36,9	35,0	-
98	-	-	-	-	34,8	32,0	-
102	-	-	-	-	32,9	29,0	-
106	-	-	-	-	-	26,0	-
110	-	-	-	-	-	22,0	-
114	-	-	-	-	-	19,0	-
118	-	-	-	-	-	15,0	-
122	-	-	-	-	-	13,0	-
126	-	-	-	-	-	-	-
130	-	-	-	-	-	-	-
134	-	-	-	-	-	-	-

72 m + 72 m

		SWSL				SFSL	HSWSL
		0 t-250 t					
		160 t					
		85°	85°	75°	65°	55°	85°
m	t	t	t	t	t	t	t
33	-	-	-	-	-	-	70,0
34	55,5	63,0	-	-	-	-	70,0
38	47,2	63,0	-	-	-	63,0	68,5
42	40,5	61,0	-	-	-	63,0	66,5
46	35,1	60,0	-	-	-	63,0	64,5
50	30,7	58,0	-	-	-	63,0	62,0
54	26,7	56,0	-	-	-	63,0	60,0
58	23,4	54,0	60,0	-	-	61,0	57,5
62	20,6	53,0	60,0	-	-	59,0	55,0
66	18,1	51,0	60,0	-	-	56,0	52,5
70	16,0	48,0	59,0	-	-	54,0	50,5
74	14,1	45,0	59,0	-	-	52,0	47,8
78	12,6	40,6	58,0	-	-	49,0	40,6
80	-	-	56,5	47,7	-	48,0	-
82	-	-	54,5	47,7	-	47,0	-
86	-	-	51,5	45,3	-	43,0	-
90	-	-	45,0	42,4	-	39,0	-
94	-	-	-	39,8	-	35,0	-
98	-	-	-	37,4	-	32,0	-
100	-	-	-	36,4	30,7	30,0	-
102	-	-	-	35,4	29,7	28,0	-
106	-	-	-	-	28,0	26,0	-
110	-	-	-	-	26,4	23,0	-
112	-	-	-	-	25,7	22,0	-
114	-	-	-	-	-	21,0	-
118	-	-	-	-	-	17,0	-
122	-	-	-	-	-	14,0	-
126	-	-	-	-	-	11,0	-
130	-	-	-	-	-	9,0	-
134	-	-	-	-	-	6,0	-
138	-	-	-	-	-	-	-

**Remarks · Bemerkungen · Remarques**

Main boom angle 85°, 75°, 65° and 55°; capacities for intermediate boom positions are calculated by the crane control system IC-1  
 Hauptauslegerwinkel 85°, 75°, 65° und 55°; Traglasten für Zwischenstellungen des Hauptauslegers werden von der Kransteuerung IC-1 berechnet  
 Jarret de flèche principale 85°, 75°, 65° et 55°; le système de commande de la grue IC-1 calcule les charges pour les positions intermédiaires de la flèche

For HSWSL a boom power-kit is required  
 Für HSWSL ist ein Ausleger-Verstärkungs-Kit erforderlich  
 Un kit à fortifier de flèche principale est nécessaire pour HSWSL

**SWSL / SFSL 15° / HSWSL** LIFTING CAPACITIES · TRAGFÄHIGKEITEN · CAPACITÉS DE LEVAGE

8,4 m 11-15 m 360° DIN/ISO

72 m + 84 m

84 m + 36 m

m	SWSL						SFSL	HSWSL
	0 t-250 t						160 t	85°
	0 t							
	180 t+					60 t ZB		
	85°	85°	75°	65°	55°			
	t	t	t	t	t	t	t	
36	-	-	-	-	-	-	52,5	
38	46,0	48,0	-	-	-	-	52,5	
42	39,3	48,0	-	-	-	48,0	51,0	
46	33,9	47,0	-	-	-	48,0	50,5	
50	29,3	46,0	-	-	-	48,0	49,4	
54	25,4	46,0	-	-	-	48,0	48,2	
58	22,0	45,0	-	-	-	48,0	47,0	
62	19,2	44,0	45,0	-	-	47,0	45,8	
66	16,7	43,0	45,0	-	-	46,0	44,6	
70	14,5	42,0	45,0	-	-	45,0	43,3	
74	12,6	40,0	45,0	-	-	44,0	41,9	
78	10,9	39,0	44,0	-	-	42,0	40,5	
82	9,5	38,0	43,0	-	-	41,0	39,2	
86	8,2	35,0	42,0	35,0	-	38,0	35,6	
90	7,1	30,2	42,0	34,9	-	35,0	30,2	
94	-	-	40,0	34,9	-	34,0	-	
98	-	-	38,0	34,9	-	32,0	-	
102	-	-	33,9	33,2	-	29,0	-	
106	-	-	-	31,3	-	26,0	-	
108	-	-	-	30,4	24,9	24,5	-	
110	-	-	-	29,5	24,2	23,0	-	
114	-	-	-	27,9	22,7	21,0	-	
118	-	-	-	-	21,3	19,0	-	
122	-	-	-	-	20,1	16,0	-	
124	-	-	-	-	19,5	15,0	-	
126	-	-	-	-	-	14,0	-	
130	-	-	-	-	-	11,0	-	
134	-	-	-	-	-	8,0	-	
138	-	-	-	-	-	6,0	-	
142	-	-	-	-	-	4,0	-	
146	-	-	-	-	-	-	-	

m	SWSL						SFSL	HSWSL
	0 t-250 t						160 t	85°
	0 t							
	180 t+					60 t ZB		
	85°	85°	75°	65°	55°			
	t	t	t	t	t	t	t	
23	-	-	-	-	-	-	129,0	
24	95,0	105,0	-	-	-	105,0	129,0	
26	85,5	102,0	-	-	-	105,0	125,0	
28	77,0	99,0	-	-	-	104,0	122,0	
30	70,5	96,0	-	-	-	104,0	118,0	
34	59,5	91,0	-	-	-	104,0	111,0	
38	51,0	87,0	-	-	-	103,0	105,0	
42	44,5	83,0	-	-	-	102,0	99,0	
44	-	-	100,0	-	-	100,5	96,0	
46	-	-	100,0	-	-	99,0	-	
50	-	-	95,0	-	-	92,0	-	
54	-	-	90,0	-	-	86,0	-	
58	-	-	86,0	-	-	81,0	-	
62	-	-	-	73,0	-	72,0	-	
66	-	-	-	67,5	-	65,0	-	
70	-	-	-	63,0	-	59,0	-	
72	-	-	-	60,5	-	56,0	-	
74	-	-	-	-	-	53,0	-	
78	-	-	-	-	-	48,0	-	
80	-	-	-	-	46,2	45,5	-	
82	-	-	-	-	44,8	43,0	-	
84	-	-	-	-	43,4	40,5	-	
86	-	-	-	-	-	38,0	-	
90	-	-	-	-	-	35,0	-	
94	-	-	-	-	-	31,0	-	
98	-	-	-	-	-	27,0	-	
102	-	-	-	-	-	23,0	-	
106	-	-	-	-	-	19,0	-	
110	-	-	-	-	-	15,0	-	
114	-	-	-	-	-	-	-	
118	-	-	-	-	-	-	-	

**Remarks · Bemerkungen · Remarques**

Main boom angle 85°, 75°, 65° and 55°; capacities for intermediate boom positions are calculated by the crane control system IC-1  
 Hauptauslegerwinkel 85°, 75°, 65° und 55°; Traglasten für Zwischenstellungen des Hauptauslegers werden von der Kransteuerung IC-1 berechnet  
 Jarret de flèche principale 85°, 75°, 65° et 55°; le système de commande de la grue IC-1 calcule les charges pour les positions intermédiaires de la flèche

For HSWSL a boom power-kit is required  
 Für HSWSL ist ein Ausleger-Verstärkungs-Kit erforderlich  
 Un kit à fortifier de flèche principale est nécessaire pour HSWSL



# SWSL / SFSL 15° / HSWSL LIFTING CAPACITIES · TRAGFÄHIGKEITEN · CAPACITÉS DE LEVAGE

8,4 m
11-15 m
360°
DIN/ISO

84 m + 48 m

		SWSL				SFSL	HSWSL
		0 t-250 t					
		160 t					
		85°	85°	75°	65°	55°	85°
m	t	t	t	t	t	t	t
26	80,0	81,5	-	-	-	-	100,0
28	75,5	81,5	-	-	-	81,0	99,5
30	68,5	79,0	-	-	-	81,0	97,5
34	57,5	76,0	-	-	-	81,0	93,0
38	49,3	72,0	-	-	-	81,0	88,5
42	42,8	69,0	-	-	-	80,0	84,5
46	37,4	66,0	-	-	-	79,0	80,5
48	35,2	65,0	78,0	-	-	79,0	78,5
50	33,1	64,0	78,0	-	-	79,0	76,5
54	29,5	61,0	77,0	-	-	75,0	72,5
56	-	-	76,0	-	-	73,0	71,0
58	-	-	74,0	-	-	71,0	-
62	-	-	72,0	-	-	67,0	-
66	-	-	68,0	-	-	63,0	-
70	-	-	65,0	60,5	-	60,0	-
74	-	-	-	56,5	-	54,0	-
78	-	-	-	52,5	-	49,0	-
82	-	-	-	49,6	-	44,0	-
84	-	-	-	48,1	-	41,5	-
86	-	-	-	-	-	39,0	-
88	-	-	-	-	38,0	37,0	-
90	-	-	-	-	36,8	35,0	-
94	-	-	-	-	34,6	32,0	-
96	-	-	-	-	33,7	30,5	-
98	-	-	-	-	-	29,0	-
102	-	-	-	-	-	26,0	-
106	-	-	-	-	-	22,0	-
110	-	-	-	-	-	19,0	-
114	-	-	-	-	-	15,0	-
118	-	-	-	-	-	12,0	-
122	-	-	-	-	-	9,0	-

84 m + 60 m

		SWSL				SFSL	HSWSL
		0 t-250 t					
		160 t					
		85°	85°	75°	65°	55°	85°
m	t	t	t	t	t	t	t
30	61,5	64,0	-	-	-	-	77,0
34	55,5	64,0	-	-	-	62,0	75,0
38	47,5	62,0	-	-	-	62,0	72,5
42	40,9	59,0	-	-	-	62,0	70,0
46	35,6	57,0	-	-	-	62,0	67,0
50	31,3	55,0	-	-	-	62,0	64,5
54	27,5	52,0	60,0	-	-	62,0	61,5
58	24,3	50,0	60,0	-	-	61,0	59,0
62	21,5	48,0	59,0	-	-	58,0	56,5
66	19,2	46,0	58,0	-	-	56,0	54,0
68	-	-	57,0	-	-	54,5	52,5
70	-	-	56,0	-	-	53,0	-
74	-	-	54,0	-	-	51,0	-
78	-	-	52,0	46,4	-	48,0	-
82	-	-	49,0	45,7	-	44,0	-
86	-	-	-	43,7	-	40,0	-
90	-	-	-	41,0	-	36,0	-
94	-	-	-	38,6	-	32,0	-
96	-	-	-	37,5	-	30,5	-
98	-	-	-	-	29,5	29,0	-
102	-	-	-	-	27,7	26,0	-
106	-	-	-	-	26,1	23,0	-
108	-	-	-	-	25,4	21,5	-
110	-	-	-	-	-	20,0	-
114	-	-	-	-	-	17,0	-
118	-	-	-	-	-	14,0	-
122	-	-	-	-	-	11,0	-
126	-	-	-	-	-	8,0	-
130	-	-	-	-	-	6,0	-
134	-	-	-	-	-	-	-
138	-	-	-	-	-	-	-

**Remarks · Bemerkungen · Remarques**

Main boom angle 85°, 75°, 65° and 55°; capacities for intermediate boom positions are calculated by the crane control system IC-1  
 Hauptauslegerwinkel 85°, 75°, 65° und 55°; Traglasten für Zwischenstellungen des Hauptauslegers werden von der Kransteuerung IC-1 berechnet  
 Jarret de flèche principale 85°, 75°, 65° et 55°; le système de commande de la grue IC-1 calcule les charges pour les positions intermédiaires de la flèche

For HSWSL a boom power-kit is required  
 Für HSWSL ist ein Ausleger-Verstärkungs-Kit erforderlich  
 Un kit à fortifier de flèche principale est nécessaire pour HSWSL

**SWSL / SFSL 15° / HSWSL** LIFTING CAPACITIES · TRAGFÄHIGKEITEN · CAPACITÉS DE LEVAGE

8,4 m 11-15 m 360° DIN/ISO

84 m + 72 m

84 m + 84 m

m	SWSL						SFSL	HSWSL
	0 t-250 t						160 t	85°
	0 t							
85°	85°	75°	65°	55°				
t	t	t	t	t	t	t	t	
34	48,0	49,0	-	-	-	-	58,5	
38	45,4	49,0	-	-	-	48,0	57,5	
42	38,9	48,0	-	-	-	48,0	55,5	
46	33,6	47,0	-	-	-	48,0	54,0	
50	29,0	45,0	-	-	-	48,0	52,5	
54	25,2	44,0	-	-	-	48,0	50,5	
58	22,0	42,0	-	-	-	48,0	49,0	
60	20,6	41,5	47,0	-	-	48,0	48,1	
62	19,2	41,0	47,0	-	-	48,0	47,2	
66	16,8	39,0	46,0	-	-	46,0	45,5	
70	14,7	38,0	46,0	-	-	45,0	43,7	
74	12,9	37,0	45,0	-	-	44,0	42,0	
78	11,4	36,0	44,0	-	-	42,0	40,3	
79	-	-	43,5	-	-	41,2	39,8	
82	-	-	43,0	-	-	39,0	-	
84	-	-	42,0	35,4	-	37,0	-	
86	-	-	41,0	35,4	-	35,0	-	
90	-	-	40,0	35,1	-	34,0	-	
94	-	-	39,0	34,2	-	32,0	-	
98	-	-	-	33,1	-	28,0	-	
102	-	-	-	31,4	-	25,0	-	
106	-	-	-	29,6	22,9	22,0	-	
110	-	-	-	-	21,5	20,0	-	
114	-	-	-	-	20,2	17,0	-	
118	-	-	-	-	19,0	15,0	-	
120	-	-	-	-	18,4	13,5	-	
122	-	-	-	-	-	12,0	-	
126	-	-	-	-	-	10,0	-	
130	-	-	-	-	-	7,0	-	
134	-	-	-	-	-	5,0	-	
138	-	-	-	-	-	-	-	
142	-	-	-	-	-	-	-	
146	-	-	-	-	-	-	-	

m	SWSL						SFSL	HSWSL
	0 t-250 t						160 t	85°
	0 t							
85°	85°	75°	65°	55°				
t	t	t	t	t	t	t	t	
37	-	-	-	-	-	-	44,5	
38	38,0	40,0	-	-	-	-	44,5	
42	36,7	40,0	-	-	-	38,0	43,8	
46	31,6	39,0	-	-	-	38,0	42,9	
50	27,3	38,0	-	-	-	38,0	41,9	
54	23,8	37,0	-	-	-	38,0	40,8	
58	20,6	36,0	-	-	-	38,0	39,6	
62	17,8	35,0	-	-	-	38,0	38,5	
66	15,4	34,0	37,0	-	-	38,0	37,3	
70	13,3	33,0	37,0	-	-	37,0	36,1	
74	11,4	32,0	37,0	-	-	37,0	34,9	
78	9,8	31,0	37,0	-	-	36,0	33,7	
82	8,4	29,0	36,0	-	-	35,0	32,5	
86	7,1	28,0	35,0	-	-	34,0	31,3	
90	6,0	27,0	35,0	-	-	32,0	30,2	
91	-	-	34,5	-	-	31,0	29,9	
92	-	-	34,0	26,5	-	30,0	-	
94	-	-	34,0	26,5	-	28,0	-	
98	-	-	33,0	26,5	-	25,0	-	
102	-	-	31,0	26,1	-	24,0	-	
104	-	-	24,7	25,8	-	23,5	-	
106	-	-	-	25,5	-	23,0	-	
110	-	-	-	24,7	-	20,0	-	
114	-	-	-	23,7	-	18,0	-	
116	-	-	-	23,3	17,3	16,5	-	
118	-	-	-	22,8	16,7	15,0	-	
122	-	-	-	-	15,6	13,0	-	
126	-	-	-	-	14,5	11,0	-	
130	-	-	-	-	13,6	9,0	-	
132	-	-	-	-	13,2	7,5	-	
134	-	-	-	-	-	6,0	-	
138	-	-	-	-	-	4,0	-	
142	-	-	-	-	-	-	-	

**Remarks · Bemerkungen · Remarques**

Main boom angle 85°, 75°, 65° and 55°; capacities for intermediate boom positions are calculated by the crane control system IC-1  
 Hauptauslegerwinkel 85°, 75°, 65° und 55°; Traglasten für Zwischenstellungen des Hauptauslegers werden von der Kransteuerung IC-1 berechnet  
 Jarret de flèche principale 85°, 75°, 65° et 55°; le système de commande de la grue IC-1 calcule les charges pour les positions intermédiaires de la flèche

For HSWSL a boom power-kit is required  
 Für HSWSL ist ein Ausleger-Verstärkungs-Kit erforderlich  
 Un kit à fortifier de flèche principale est nécessaire pour HSWSL



# SWSL / SFSL 15° / HSWSL LIFTING CAPACITIES · TRAGFÄHIGKEITEN · CAPACITÉS DE LEVAGE

8,4 m 11-15 m 360° DIN/ISO

96 m + 36 m

		SWSL					SFSL	HSWSL
		0 t-250 t						
		160 t						
		85°	85°	75°	65°	55°		85°
m	t	t	t	t	t	t	t	t
24	78,5	81,0	-	-	-	-	-	99,5
26	78,5	81,0	-	-	-	-	80,0	98,0
28	74,5	77,5	-	-	-	-	79,5	95,5
30	68,0	75,0	-	-	-	-	78,5	92,5
34	57,0	70,0	-	-	-	-	76,5	87,0
38	49,2	65,5	-	-	-	-	74,5	81,5
42	42,8	62,0	-	-	-	-	72,0	76,5
45	-	-	-	-	-	-	70,1	73,0
46	-	-	67,5	-	-	-	69,5	-
50	-	-	65,5	-	-	-	66,5	-
54	-	-	62,0	-	-	-	64,0	-
58	-	-	59,0	-	-	-	62,0	-
62	-	-	54,5	-	-	-	60,0	-
66	-	-	-	-	-	-	58,0	-
68	-	-	-	52,5	-	-	57,0	-
70	-	-	-	51,5	-	-	56,0	-
74	-	-	-	48,1	-	-	50,0	-
78	-	-	-	44,3	-	-	44,7	-
82	-	-	-	-	-	-	39,9	-
86	-	-	-	-	35,8	-	35,5	-
90	-	-	-	-	33,6	-	31,6	-
92	-	-	-	-	32,6	-	29,8	-
94	-	-	-	-	-	-	28,0	-
98	-	-	-	-	-	-	24,7	-
102	-	-	-	-	-	-	21,4	-
106	-	-	-	-	-	-	17,8	-
110	-	-	-	-	-	-	14,3	-
114	-	-	-	-	-	-	10,8	-
118	-	-	-	-	-	-	7,8	-
122	-	-	-	-	-	-	-	-
126	-	-	-	-	-	-	-	-
130	-	-	-	-	-	-	-	-
134	-	-	-	-	-	-	-	-

96 m + 48 m

		SWSL					SFSL	HSWSL
		0 t-250 t						
		160 t						
		85°	85°	75°	65°	55°		85°
m	t	t	t	t	t	t	t	t
27	-	-	-	-	-	-	-	76,5
28	60,5	60,5	-	-	-	-	-	76,5
30	60,5	60,5	-	-	-	-	61,5	75,5
34	55,5	57,0	-	-	-	-	60,5	72,0
38	47,5	54,0	-	-	-	-	59,0	68,5
42	41,0	51,0	-	-	-	-	58,0	65,0
46	35,9	48,6	-	-	-	-	56,0	61,5
50	31,6	46,2	-	-	-	-	54,0	58,5
52	29,8	45,0	52,0	-	-	-	53,2	56,7
54	28,1	43,8	52,0	-	-	-	52,5	55,0
57	-	-	50,5	-	-	-	50,6	53,0
58	-	-	50,0	-	-	-	50,0	-
62	-	-	48,0	-	-	-	49,0	-
66	-	-	46,0	-	-	-	47,0	-
70	-	-	43,0	-	-	-	46,0	-
74	-	-	41,0	40,5	-	-	44,0	-
78	-	-	-	39,4	-	-	43,0	-
82	-	-	-	37,0	-	-	41,0	-
86	-	-	-	34,6	-	-	36,7	-
88	-	-	-	33,3	-	-	34,7	-
90	-	-	-	-	-	-	32,7	-
94	-	-	-	-	-	-	29,0	-
96	-	-	-	-	27,9	-	27,3	-
98	-	-	-	-	27,0	-	25,7	-
102	-	-	-	-	25,4	-	22,6	-
104	-	-	-	-	24,7	-	21,2	-
106	-	-	-	-	-	-	19,8	-
110	-	-	-	-	-	-	16,8	-
114	-	-	-	-	-	-	13,7	-
118	-	-	-	-	-	-	10,7	-
122	-	-	-	-	-	-	7,8	-
126	-	-	-	-	-	-	4,9	-
130	-	-	-	-	-	-	-	-

**Remarks · Bemerkungen · Remarques**

Main boom angle 85°, 75°, 65° and 55°; capacities for intermediate boom positions are calculated by the crane control system IC-1  
 Hauptauslegerwinkel 85°, 75°, 65° und 55°; Traglasten für Zwischenstellungen des Hauptauslegers werden von der Kransteuerung IC-1 berechnet  
 Jarret de flèche principale 85°, 75°, 65° et 55°; le système de commande de la grue IC-1 calcule les charges pour les positions intermédiaires de la flèche

For HSWSL a boom power-kit is required  
 Für HSWSL ist ein Ausleger-Verstärkungs-Kit erforderlich  
 Un kit à fortifier de flèche principale est nécessaire pour HSWSL

**SWSL / SFSL 15° / HSWSL** LIFTING CAPACITIES · TRAGFÄHIGKEITEN · CAPACITÉS DE LEVAGE

8,4 m 11-15 m 360° DIN/ISO

96 m + 60 m

m	SWSL					SFSL	HSWSL
	0 t-250 t					160 t	
	85°	85°	75°	65°	55°	t	t
31	-	-	-	-	-	-	60,0
34	45,9	45,9	-	-	-	47,3	59,0
38	44,1	44,1	-	-	-	46,4	56,5
42	39,2	42,1	-	-	-	45,5	54,0
46	34,0	40,1	-	-	-	44,6	51,5
50	29,6	38,2	-	-	-	43,3	49,2
54	25,9	36,2	-	-	-	43,0	46,8
58	22,8	34,6	41,0	-	-	42,0	44,6
62	20,1	33,0	41,0	-	-	41,0	42,4
66	17,8	31,2	40,0	-	-	40,0	40,2
69	-	-	38,5	-	-	39,2	38,6
70	-	-	38,0	-	-	39,0	-
74	-	-	37,0	-	-	37,0	-
78	-	-	35,0	-	-	36,0	-
82	-	-	33,0	29,8	-	35,0	-
84	-	-	28,6	29,6	-	34,5	-
86	-	-	-	29,3	-	34,0	-
90	-	-	-	27,6	-	33,0	-
94	-	-	-	25,8	-	29,4	-
98	-	-	-	24,1	-	26,0	-
100	-	-	-	23,4	-	24,4	-
102	-	-	-	-	-	22,9	-
104	-	-	-	-	20,6	21,4	-
106	-	-	-	-	20,6	20,0	-
110	-	-	-	-	19,3	17,4	-
114	-	-	-	-	17,9	14,6	-
118	-	-	-	-	-	11,9	-
122	-	-	-	-	-	9,2	-
126	-	-	-	-	-	6,6	-
130	-	-	-	-	-	4,1	-
134	-	-	-	-	-	-	-

96 m + 72 m

m	SWSL					SFSL	HSWSL
	0 t-250 t					160 t	
	85°	85°	75°	65°	55°	t	t
35	-	-	-	-	-	-	45,8
38	35,3	35,3	-	-	-	36,3	45,1
42	34,1	34,1	-	-	-	35,7	43,6
46	31,0	32,8	-	-	-	35,0	42,0
50	26,9	31,4	-	-	-	34,2	40,4
54	23,5	29,9	-	-	-	33,3	38,7
58	20,4	28,4	-	-	-	33,0	37,1
62	17,7	27,0	-	-	-	33,0	35,5
64	16,5	26,5	32,0	-	-	32,5	34,7
66	15,4	26,0	32,0	-	-	32,0	34,0
70	13,4	25,0	31,0	-	-	31,0	32,5
74	11,6	24,0	30,0	-	-	30,0	30,9
78	10,1	23,0	29,0	-	-	30,0	29,4
80	-	-	29,0	-	-	29,5	28,7
82	-	-	28,0	-	-	29,0	-
86	-	-	27,0	-	-	28,0	-
90	-	-	26,0	22,2	-	27,0	-
94	-	-	24,2	21,8	-	26,0	-
96	-	-	20,6	21,4	-	25,5	-
98	-	-	-	20,8	-	25,0	-
102	-	-	-	19,5	-	22,7	-
106	-	-	-	18,1	-	19,0	-
110	-	-	-	16,9	-	17,0	-
112	-	-	-	16,3	-	15,7	-
114	-	-	-	-	14,5	14,5	-
118	-	-	-	-	13,9	11,9	-
122	-	-	-	-	12,9	9,5	-
126	-	-	-	-	11,9	7,1	-
130	-	-	-	-	-	4,8	-
134	-	-	-	-	-	-	-
138	-	-	-	-	-	-	-

**Remarks · Bemerkungen · Remarques**

Main boom angle 85°, 75°, 65° and 55°; capacities for intermediate boom positions are calculated by the crane control system IC-1  
 Hauptauslegerwinkel 85°, 75°, 65° und 55°; Traglasten für Zwischenstellungen des Hauptauslegers werden von der Kransteuerung IC-1 berechnet  
 Jarret de flèche principale 85°, 75°, 65° et 55°; le système de commande de la grue IC-1 calcule les charges pour les positions intermédiaires de la flèche

For HSWSL a boom power-kit is required  
 Für HSWSL ist ein Ausleger-Verstärkungs-Kit erforderlich  
 Un kit à fortifier de flèche principale est nécessaire pour HSWSL



# SWSL / SFSL 15° / HSWSL LIFTING CAPACITIES · TRAGFÄHIGKEITEN · CAPACITÉS DE LEVAGE

8,4 m    11-15 m    360°    DIN/ISO

96 m + 84 m

m	SWSL						SFSL	HSWSL
	0 t-250 t							
	160 t							
	85°	85°	75°	65°	55°		85°	
t	t	t	t	t	t	t	t	
38	27,3	27,3	-	-	-	-	33,3	
42	27,3	27,3	-	-	-	27,7	33,3	
46	26,1	26,1	-	-	-	27,2	33,3	
50	24,6	25,0	-	-	-	26,5	32,2	
54	21,3	24,0	-	-	-	26,0	31,1	
58	18,4	23,0	-	-	-	26,0	29,9	
62	16,0	22,0	-	-	-	26,0	28,8	
66	13,9	21,0	-	-	-	25,0	27,6	
68	12,9	21,0	24,0	-	-	25,0	27,0	
70	12,0	21,0	24,0	-	-	25,0	26,5	
74	10,2	20,0	24,0	-	-	24,0	25,4	
78	8,6	19,0	23,0	-	-	23,0	24,4	
82	7,2	18,0	23,0	-	-	23,0	23,4	
86	6,0	17,0	22,0	-	-	22,0	22,3	
90	4,9	17,0	21,0	-	-	21,0	21,3	
92	-	-	21,0	-	-	21,0	20,8	
94	-	-	20,0	-	-	21,0	-	
96	-	-	20,0	15,5	-	20,5	-	
98	-	-	20,0	15,5	-	20,0	-	
102	-	-	18,5	15,3	-	19,0	-	
106	-	-	14,5	14,7	-	18,0	-	
108	-	-	14,1	14,3	-	17,5	-	
110	-	-	-	13,9	-	17,0	-	
114	-	-	-	13,1	-	10,9	-	
118	-	-	-	12,4	-	-	-	
122	-	-	-	11,6	9,5	-	-	
124	-	-	-	11,2	9,5	-	-	
126	-	-	-	-	9,4	-	-	
130	-	-	-	-	8,7	-	-	
134	-	-	-	-	7,8	-	-	
138	-	-	-	-	6,9	-	-	

96 m + 96 m

m	SWSL						SFSL	HSWSL
	0 t-250 t							
	160 t							
	85°	85°	75°	65°	55°		85°	
t	t	t	t	t	t	t	t	
42	19,4	19,4	-	-	-	-	-	
46	19,4	19,4	-	-	-	19,8	-	
50	18,5	19,0	-	-	-	19,4	-	
54	18,0	18,0	-	-	-	19,0	-	
58	16,9	18,0	-	-	-	19,0	-	
62	14,5	17,0	-	-	-	19,0	-	
66	12,4	16,0	-	-	-	19,0	-	
70	10,6	16,0	-	-	-	18,0	-	
74	9,0	15,0	17,0	-	-	18,0	-	
78	7,5	15,0	17,0	-	-	18,0	-	
82	6,3	14,0	17,0	-	-	17,0	-	
86	5,1	13,0	17,0	-	-	16,0	-	
90	-	13,0	16,0	-	-	16,0	-	
94	-	12,0	16,0	-	-	15,0	-	
98	-	11,0	15,0	-	-	15,0	-	
102	-	11,0	14,5	-	-	14,0	-	
104	-	-	14,0	9,5	-	14,0	-	
106	-	-	14,0	9,5	-	14,0	-	
110	-	-	13,5	9,3	-	13,0	-	
114	-	-	12,5	8,9	-	13,0	-	
118	-	-	8,7	8,4	-	12,0	-	
120	-	-	8,3	8,1	-	11,4	-	
122	-	-	-	7,8	-	10,9	-	
126	-	-	-	7,3	-	-	-	
130	-	-	-	6,7	4,4	-	-	
134	-	-	-	6,2	4,3	-	-	
136	-	-	-	5,9	4,2	-	-	
138	-	-	-	-	4,1	-	-	
142	-	-	-	-	-	-	-	
146	-	-	-	-	-	-	-	
150	-	-	-	-	-	-	-	

**Remarks · Bemerkungen · Remarques**

Main boom angle 85°, 75°, 65° and 55°; capacities for intermediate boom positions are calculated by the crane control system IC-1  
 Hauptauslegerwinkel 85°, 75°, 65° und 55°; Traglasten für Zwischenstellungen des Hauptauslegers werden von der Kransteuerung IC-1 berechnet  
 Jarret de flèche principale 85°, 75°, 65° et 55°; le système de commande de la grue IC-1 calcule les charges pour les positions intermédiaires de la flèche

For HSWSL a boom power-kit is required  
 Für HSWSL ist ein Ausleger-Verstärkungs-Kit erforderlich  
 Un kit à fortifier de flèche principale est nécessaire pour HSWSL



**SWSL / SFSL 15° / HSWSL** LIFTING CAPACITIES · TRAGFÄHIGKEITEN · CAPACITÉS DE LEVAGE

8,4 m 11-15 m 360° DIN/ISO

108 m + 36 m

m	SWSL						SFSL	HSWSL
	0 t-250 t						160 t	85°
	85°	85°	75°	65°	55°	85°		
t	t	t	t	t	t	t	t	
25	-	-	-	-	-	-	74,5	
26	-	-	-	-	-	-	74,5	
28	-	-	-	-	-	-	72,0	
30	-	-	-	-	-	-	70,0	
34	-	-	-	-	-	-	65,5	
38	-	-	-	-	-	-	61,0	
42	-	-	-	-	-	-	57,0	
46	-	-	-	-	-	-	53,0	
50	-	-	-	-	-	-	-	

108 m + 60 m

m	SWSL						SFSL	HSWSL
	0 t-250 t						160 t	85°
	85°	85°	75°	65°	55°	85°		
t	t	t	t	t	t	t	t	
32	-	-	-	-	-	-	43,9	
34	32,5	33,7	-	-	-	37,7	43,9	
38	31,2	32,2	-	-	-	37,2	41,9	
42	29,9	30,7	-	-	-	36,1	39,8	
46	28,5	29,2	-	-	-	35,1	37,6	
50	27,1	27,7	-	-	-	34,0	35,5	
54	24,1	26,2	-	-	-	32,6	33,3	
58	21,1	24,9	-	-	-	31,2	31,6	
60	19,8	24,2	29,5	-	-	30,5	30,7	
62	18,5	23,6	29,3	-	-	29,8	29,9	
66	16,3	22,3	28,3	-	-	28,2	28,2	
70	14,4	20,2	26,6	-	-	26,6	26,5	
74	-	-	24,9	-	-	24,9	-	
78	-	-	23,3	-	-	23,3	-	
82	-	-	21,6	-	-	21,6	-	
86	-	-	20,0	-	-	19,9	-	
88	-	-	19,2	18,1	-	19,1	-	
90	-	-	-	18,1	-	18,3	-	
94	-	-	-	16,8	-	16,6	-	
98	-	-	-	15,4	-	14,8	-	
102	-	-	-	14,0	-	12,9	-	
106	-	-	-	12,7	-	-	-	
112	-	-	-	-	8,5	-	-	
114	-	-	-	-	8,5	-	-	
118	-	-	-	-	7,5	-	-	
122	-	-	-	-	6,5	-	-	
126	-	-	-	-	-	-	-	

108 m + 48 m

m	t	t	t	t	t	t	t
28	42,8	44,2	-	-	-	-	57,5
30	42,8	44,2	-	-	-	48,9	57,5
34	41,0	42,1	-	-	-	48,2	54,0
38	39,0	40,0	-	-	-	46,8	51,0
42	37,1	37,9	-	-	-	45,4	48,3
46	34,1	35,7	-	-	-	43,8	45,3
50	29,9	33,9	-	-	-	42,0	42,7
54	26,3	32,2	-	-	-	40,2	40,2
56	24,8	31,3	38,4	-	-	39,2	38,9
58	23,3	30,4	38,4	-	-	38,3	37,6
62	-	-	36,1	-	-	36,2	-
66	-	-	33,7	-	-	34,2	-
70	-	-	31,4	-	-	32,1	-
74	-	-	29,1	-	-	30,0	-
76	-	-	28,0	-	-	28,9	-
78	-	-	-	-	-	27,9	-
80	-	-	-	25,1	-	26,8	-
82	-	-	-	24,9	-	25,8	-
86	-	-	-	23,7	-	23,7	-
90	-	-	-	21,8	-	21,2	-
94	-	-	-	20,0	-	19,1	-
102	-	-	-	-	14,2	-	-
106	-	-	-	-	13,8	-	-
110	-	-	-	-	12,5	-	-
114	-	-	-	-	-	-	-

**Remarks · Bemerkungen · Remarques**

Main boom angle 85°, 75°, 65° and 55°; capacities for intermediate boom positions are calculated by the crane control system IC-1  
 Hauptauslegerwinkel 85°, 75°, 65° und 55°; Traglasten für Zwischenstellungen des Hauptauslegers werden von der Kransteuerung IC-1 berechnet  
 Jarret de flèche principale 85°, 75°, 65° et 55°; le système de commande de la grue IC-1 calcule les charges pour les positions intermédiaires de la flèche

For HSWSL a boom power-kit is required  
 Für HSWSL ist ein Ausleger-Verstärkungs-Kit erforderlich  
 Un kit à fortifier de flèche principale est nécessaire pour HSWSL



**SFVL / LFVL WORKING RANGES · ARBEITSBEREICHE · PORTÉES** **13°**

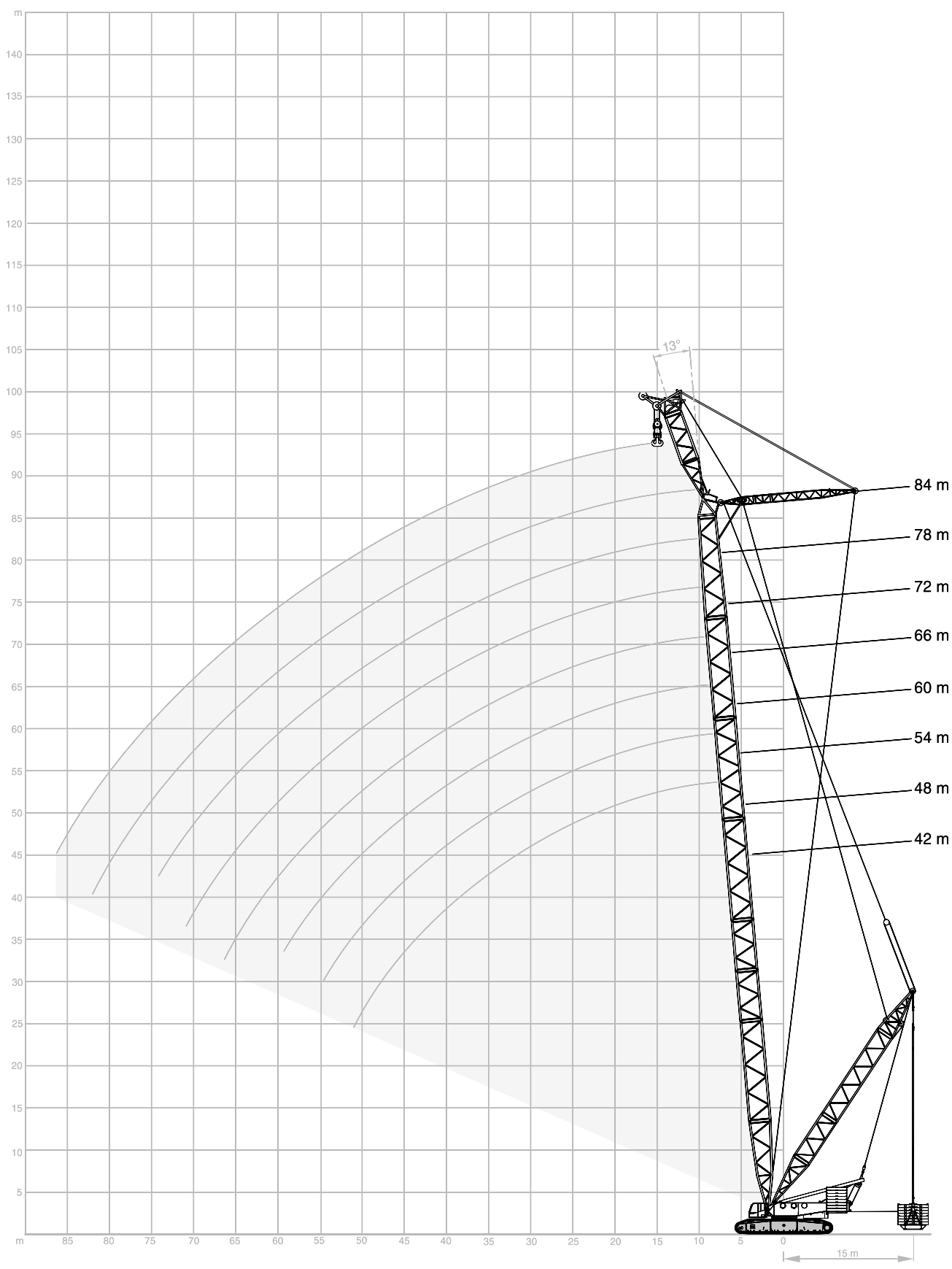

**SFVL / LFVL LIFTING CAPACITIES · TRAGFÄHIGKEITEN · CAPACITÉS DE LEVAGE**

180 t + 60 t ZB 11-15 m 0-300 t 12 m 8,40 m 360° DIN/ISO

m	42 m			48 m			54 m			60 m		
	SFVL		LFVL	SFVL		LFVL	SFVL		LFVL	SFVL		LFVL
	13°	20°	17,5°	13°	20°	17,5°	13°	20°	17,5°	13°	20°	17,5°
	t	t	t	t	t	t	t	t	t	t	t	t
13	462,0	-	300,0	429,0	-	300,0	-	-	300,0	-	-	-
14	448,0	438,0	300,0	428,0	412,0	300,0	387,0	369,0	300,0	350,0	-	300,0
16	422,0	418,0	300,0	417,0	401,0	300,0	385,0	369,0	300,0	348,0	334,0	300,0
18	394,0	394,0	300,0	394,0	390,0	300,0	383,0	366,0	300,0	346,0	329,0	300,0
20	349,0	355,0	300,0	352,0	353,0	300,0	350,0	351,0	300,0	341,0	324,0	300,0
22	317,0	318,0	291,0	315,0	316,0	296,0	313,0	314,0	300,0	311,0	310,0	300,0
24	286,0	287,0	269,0	284,0	285,0	280,0	282,0	283,0	278,0	280,0	281,0	282,0
26	260,0	261,0	249,0	264,0	262,0	260,0	262,0	260,0	261,0	254,0	256,0	259,0
28	239,0	239,0	230,0	242,0	243,0	240,0	241,0	242,0	241,0	239,0	238,0	240,0
30	220,0	221,0	212,0	221,0	222,0	221,0	220,0	221,0	220,0	218,0	219,0	219,0
34	189,0	190,0	180,0	188,0	188,0	188,0	186,0	187,0	186,0	184,0	185,0	185,0
38	160,0	163,0	152,0	162,0	162,0	160,0	160,0	161,0	161,0	159,0	159,0	159,0
42	138,0	138,0	131,0	142,0	142,0	137,0	140,0	141,0	140,0	138,0	139,0	139,0
46	114,0	114,0	115,0	124,0	124,0	119,0	124,0	124,0	124,0	122,0	122,0	122,0
50	92,5	-	97,5	104,0	104,0	105,0	110,0	111,0	108,0	109,0	109,0	109,0
54	-	-	-	86,5	-	91,5	95,0	95,0	96,0	97,5	98,0	97,5
58	-	-	-	-	-	-	80,0	80,0	85,0	85,0	85,0	87,0
62	-	-	-	-	-	-	-	-	-	72,5	72,5	77,5
66	-	-	-	-	-	-	-	-	-	60,5	-	-

m	66 m			72 m			78 m			84 m		
	SFVL		LFVL	SFVL		LFVL	SFVL		LFVL	SFVL		LFVL
	13°	20°	17,5°	13°	20°	17,5°	13°	20°	17,5°	13°	20°	17,5°
	t	t	t	t	t	t	t	t	t	t	t	t
14	-	-	277,0	-	-	-	-	-	-	-	-	-
15	296,0	-	277,0	-	-	-	-	-	-	-	-	-
16	295,0	284,0	277,0	259,0	252,0	245,0	219,0	211,0	205,0	-	-	181,0
17	294,0	283,0	277,0	258,0	251,0	245,0	218,0	211,0	205,0	193,0	-	181,0
18	293,0	282,0	277,0	258,0	250,0	245,0	217,0	211,0	205,0	192,0	187,0	181,0
20	291,0	280,0	277,0	257,0	249,0	245,0	215,0	209,0	205,0	190,0	185,0	181,0
22	282,0	277,0	275,0	254,0	247,0	245,0	213,0	207,0	205,0	189,0	183,0	181,0
24	270,0	267,0	262,0	246,0	242,0	240,0	211,0	205,0	204,0	186,0	182,0	181,0
26	253,0	254,0	249,0	239,0	235,0	232,0	208,0	203,0	202,0	183,0	179,0	179,0
28	231,0	232,0	236,0	229,0	229,0	224,0	205,0	200,0	199,0	179,0	176,0	177,0
30	217,0	216,0	217,0	210,0	211,0	215,0	202,0	197,0	197,0	176,0	172,0	175,0
34	183,0	184,0	183,0	181,0	182,0	182,0	178,0	179,0	180,0	165,0	164,0	168,0
38	157,0	158,0	157,0	155,0	156,0	156,0	154,0	155,0	154,0	149,0	149,0	153,0
42	137,0	137,0	137,0	135,0	136,0	135,0	134,0	134,0	134,0	132,0	133,0	132,0
46	121,0	121,0	121,0	119,0	119,0	119,0	117,0	118,0	117,0	115,0	116,0	116,0
50	107,0	107,0	107,0	105,0	106,0	105,0	104,0	104,0	104,0	102,0	102,0	102,0
54	96,0	96,5	96,0	94,0	94,5	94,0	92,5	93,0	92,5	90,5	91,0	91,0
58	86,5	86,5	86,5	84,5	85,0	84,5	83,0	83,5	83,0	81,0	81,5	81,0
62	76,0	76,0	78,5	76,5	76,5	76,5	74,5	75,0	75,0	73,0	73,0	73,0
66	65,0	65,0	70,0	66,5	66,5	69,5	66,5	66,5	67,5	65,0	65,0	66,0
70	55,0	-	60,0	57,5	57,5	62,5	58,0	58,0	61,5	57,0	57,0	59,5
74	-	-	-	48,9	-	53,5	50,5	50,5	55,5	50,0	50,0	53,5
78	-	-	-	-	-	-	43,1	43,1	48,1	43,3	43,3	48,3
82	-	-	-	-	-	-	35,7	-	-	36,8	36,8	41,8
86	-	-	-	-	-	-	-	-	-	30,4	-	-

5

## TECHNICAL DESCRIPTION

### CRAWLER CARRIER

	3-section carrier comprising of carbody and two crawlers. Hydraulic pin connections between crawlers and carbody provide for easy assembly and removal to minimise width and weight for transportation.
<b>Carbody</b>	Bending- and torsion-resistant welded structure of box type construction, fabricated of high-strength fine-grain structural steel.
<b>Crawlers</b>	Side frames: bending-resistant welded structure of high-strength fine-grain structural steel. Track shoes, idler and drive sprockets are fabricated of heat-treated high-strength cast steel. 15 rollers on each side frame with hardened rolling surfaces. Automatic centralized lubrication is included as standard.
<b>Power train</b>	The tracks are powered by two hydraulic motors each through closed planetary gear reduction units running in oil bath, equipped with spring-applied hydraulically released holding brakes; the gear units are of very compact design to fit within the width of the crawlers. Each crawler is infinitely variable controlled, both independently and in opposite direction.
<b>Assembly jacks</b>	Four hydraulic jacking cylinders on carbody (folding within 3 m width) for easy assembly of crawlers.

### SUPERSTRUCTURE

<b>Counterweight</b>	160 t / 180 t as option in combination with central ballast.
<b>Frame</b>	Torsion-resistant welded structure fabricated of high-strength fine-grain structural steel. Connected to carrier by triple-row roller bearing slew ring.
<b>Drive</b>	DaimlerChrysler diesel engine type OM 502 LA, 390 kW (530 hp) at 1800 1/min, torque 2400 Nm at 1300 1/min. The engine complies with EUROMOT 3a, EPA T3 and Carb regulations. Pump distribution gearbox with five variable displacement axial piston pumps, and gear pumps. Silencer with spark-arrestor.
<b>Rope drums</b>	The standard superstructure equipment includes three rope drums – hoist 1, hoist 2 and boom hoist. The drums are powered by hydraulic motors through closed planetary gear units running in oil bath. All rope drums have spring-applied, hydraulically released multi-disk brakes and non-wearing hydraulic braking for load lowering. Rope ends H 1, 2, 3 and W 1, 2 equipped with quick-connect rope end fittings. Hoists H 1 + 2 are removable to minimise weight for transportation.
<b>A-frame</b>	Hydraulic raising system for A-frame as standard.
<b>Slew unit</b>	Powered by hydraulic motor through closed, planetary gear unit running in oil bath. Spring-applied, hydraulically released holding brake and non-wearing hydraulic braking.
<b>Control system</b>	Demag IC-1: Electronic proportional valve pilot control integrated in stored-program control system incl. diagnostics. 2 colour monitors, safe load indicator operated via a touchscreen. Working speeds infinitely variable controlled by the lever position. Automatic power control for optimal utilisation of engine output, emergency control system.
<b>Cabin</b>	Comfortable cab with large windscreen and airconditioner. Safety-glazing all around, roof window, self-contained hot air heater, full instrumentation and crane controls. The cab can be tilted back for improved operator view of boom point. A camera system is installed to monitor the rope drums. For transportation, the cab swings in front of the superstructure to minimise width.
<b>Electrical equipment</b>	24 V d. c. system (2 x batteries 12 V, 200 Ah).

### OPTIONAL EQUIPMENT

<b>Counterweight</b>	20 t on the superstructure (only in conjunction with central ballast).
<b>Central ballast</b>	60 t.
<b>Hydraulic cylinder A-frame</b>	For self-assembly of crawlers.
<b>Sideways outriggers</b>	For erection of long boom systems.
<b>Counterweight carrier</b>	Drive 4 x 4, total weight 320 t, net weight 40 t, in combination with SL telescopic system.
<b>Quick-connection</b>	Hydraulic quick-disconnect fittings on carrier and superstructure facilitate removal to minimise weight for transportation.
<b>Track shoes</b>	2000 mm.
<b>Quadro-drive</b>	Add. two hydraulic motors on the crawlers to double the driving power. The driving speed will be reduced accordingly.

**TECHNICAL DESCRIPTION**

**BOOM CONFIGURATIONS S AND L**

<b>SH:</b>	Main boom: foot section 10.5 m (used to install drums W1/H3), inserts 12 m and 6 m (type 2724) and tapered insert 12 m, head with sheave assembly 600 t 1.5 m. Main boom lengths: 24-84 m.
<b>SH/LH:</b>	Main boom: same as SH, extended by type 2421 from the fly jib and by top section 7.5 m. Main boom lengths: 66-102 m.
<b>SW:</b>	Main boom: same as SH. Fly jib: foot section 4.5 m, inserts 12 m and 6 m (type 2421) and top section 7.5 m. Main boom lengths: 30-66 m. Fly jib lengths: 24-84 m.
<b>SSL:</b>	Main boom: same as SH. Superlift equipment, Superlift counterweight 0-300 t (at 50 t increments). Main boom lengths: 36-84 m.
<b>HSSL:</b>	Main Boom: same as SH/SSL + boom power-kit. Superlift equipment, Superlift counterweight 0-300 t (at 50 t increments). Main boom lengths: 54-108 m.
<b>SSL/LSL:</b>	Main boom: same as SH 84 m, extended by type 2421 from the fly jib and by top section 7.5 m. Superlift equipment, Superlift counterweight 0-300 t (at 50 t increments). Main boom lengths: 90-138 m.
<b>SWSL: (SFSL)</b>	Main boom: same as SH. Fly jib: same as SW. Superlift equipment, Superlift counterweight 0-300 t (at 50 t increments). Main boom lengths: 36-84 m. Fly jib lengths: 24-84 m.
<b>HSWSL:</b>	Main Boom: same as HSSL. Fly jib: same as SW/SWSL. Superlift equipment, Superlift counterweight 0-300 t (at 50 t increments). Main boom lengths: 54-108 m. Fly jib lengths: 24-96 m.
<b>LF2:</b>	Main boom: same as SH, SSL, HSSL, SH/LH, SH/LH SGLmax; SSL/LSL, SSL/LSL SGLmax. Fly jib lengths: 12, 24, 36 m. Fly jib offsets: 10°, 15°, 20° for jib length 12 m. Fly jib offsets: 10°, 20°, 30° for jib lengths 24-36 m.
<b>SFVL:</b>	Main boom: same as SH, lengths 42-84 m, without sheave assembly. Fly jib: foot section 4.5 m, insert 6 m; heavy-duty head 1.5 m. Sheave assembly 600 t same as SH.
<b>SH/LH SGLmax:</b>	Same as SH, extended by boom power-kit + jib top section. Main boom lengths: 78-108 m.
<b>SSL/LSL SGLmax:</b>	Same as SSL, extended by boom power-kit + jib top section. Main boom lengths: 90-138 m.
<b>Reeving winch</b>	Mounted on superstructure
<b>Operator aids</b>	Electronic safe load indicator, hoist limit switch, limit switches for boom movements, hydraulic boom backstops, anemometer.

**OPTIONAL EQUIPMENT**

<b>Power-kit for main boom</b>	Consisting of 2-4 additional heavy main boom sections; standard main boom 84 m required.
<b>Superlift equipment standard</b>	Mast 30 m, winch with rope and tray for 300 t. Mast radii 11, 13 and 15 m by adjusting the Superlift mast.
<b>Superlift equipment with telescopic cylinder</b>	Mast 30 m, winch with rope, SL telescopic cylinder and tray for 300 t. Mast position 15 m. Superlift counterweight can be adjusted from 13 to 17 m.
<b>Hoist H3</b>	Additional rope drum on main boom (for LF2 or runner operation). Line pull same as H1, rope length 650 m.
<b>Runner 30 t</b>	Approx. 2 m for installation on boom head or top section (not in conjunction with LF2).
<b>Runner 60 t</b>	
<b>Hydraulic pinning of boom sections</b>	



## TECHNISCHE BESCHREIBUNG

### RAUPENUNTERWAGEN

<b>Mittelstück</b>	Der Raupenunterwagen ist 3-teilig und besteht aus dem Mittelstück und zwei Raupen. Mittelstück und Raupen werden hydraulisch verbolzt und sind demontierbar zum Erreichen günstiger Transportabmessungen und Gewichte.
<b>Raupen</b>	Biege- und verwindungssteife Schweißkonstruktion in Zellenbauweise aus hochfestem Feinkornbaustahl.
<b>Antrieb</b>	Raupenträger: Biegesteife Schweißkonstruktion aus hochfestem Feinkornbaustahl. Bodenplatten der Raupenkettens, Turas und Leitrad aus vergütetem hochfestem Stahlguss. 15 Laufrollen je Raupe mit gehärteten Laufflächen. Zentralschmieranlage serienmäßig.
<b>Montageabstützung</b>	Die Raupen werden von je zwei Hydromotoren über geschlossene, ölbadgeschmierte Planetengetriebe mit federbelasteten, hydraulisch gelüfteten Haltebremsen angetrieben. Die Getriebe sind in besonders kompakter Bauform innerhalb der Raupenbreite angeordnet. Jede Seite ist stufenlos, einzeln und gegenläufig steuerbar.
<b>Montageabstützung</b>	Vier hydraulische Stützzylinder am Mittelstück (in 3 m anklappbar) zur einfachen Montage der Raupen.

### OBERWAGEN

<b>Gegengewicht</b>	160 t / 180 t optional in Verbindung mit Zentralballast am Unterwagen.
<b>Rahmen</b>	Verformungssteife Schweißkonstruktion aus hochfestem Feinkornbaustahl. Verbindung zum Unterwagen durch 3-reihige Rollendrehverbindung.
<b>Antrieb</b>	DaimlerChrysler Dieselmotor Typ OM 502 LA, 390 kW (530 PS) bei 1800 1/min, Drehmoment 2400 Nm bei 1300 1/min. Der Motor erfüllt EUROMOT 3a, EPA T3 und Carb-Vorschriften. Pumpenverteilergetriebe mit fünf verstellbaren Axialkolbenpumpen und zusätzlichen Zahnradpumpen. Schalldämpfer mit Funkenfänger.
<b>Seilwinden</b>	Der Oberwagen ist serienmäßig mit drei Seilwinden – Hubwerk 1, Hubwerk 2 und Einziehwerk – ausgerüstet. Der Antrieb der Winden erfolgt durch Hydromotoren über geschlossene, ölbadgeschmierte Planetengetriebe. Alle Seilwinden sind mit federbelasteten, hydraulisch gelüfteten Lamellenbremsen und verschleißfreier, hydraulischer Bremsung für den Senkvorgang ausgerüstet. Die Seilenden H 1, 2, 3 und W 1, 2 sind mit Preßfitting und Taschen ausgestattet. Zur Reduzierung der Transportgewichte sind die Winden H 1 + 2 ausbaubar.
<b>A-Bock</b>	Hydraulische A-Bock-Umlage serienmäßig.
<b>Drehwerk</b>	Ein Drehwerk mit Antrieb durch Hydromotor über geschlossenes, ölbadgeschmiertes Planetengetriebe. Federbelastete, hydraulisch gelüftete Haltebremse und verschleißfreie hydraulische Bremsung.
<b>Steuerung</b>	Demag IC-1: Elektronische Proportionalventilvorsteuerung integriert in eine speicherprogrammierte Steuerung mit Fehlerdiagnose. Zwei Farbbildschirme, Bedienung über Touchscreen. Die Arbeitsgeschwindigkeiten werden durch die Hebelstellung stufenlos geregelt. Leistungsregelung der Antriebe zur optimalen Nutzung der Motorleistung, Notsteuerung.
<b>Kabine</b>	Komfortkabine mit großem Frontfenster und Klimaanlage. Sicherheitsverglasung rundum, Dachfenster, motorunabhängige Warmluftheizung und Steuer- und Kontrollelementen für die Kranfunktionen. Die Kabine ist zur Sichtverbesserung nach hinten neigbar. Zur Überwachung der Winden im Oberwagen ist ein Kamerasystem installiert. Während des Transportes ist die Kabine vor den Oberwagen geschwenkt.
<b>Elektrische Anlage</b>	24 V Gleichstrom (2 x Batterie 12 V, 200 Ah).

### ZUSATZAUSRÜSTUNG

<b>Gegengewicht</b>	20 t am Oberwagen (nur in Verbindung mit Zentralballast)
<b>Zentralballast</b>	60 t.
<b>Zylinder am A-Bock</b>	Zur Raupenträger-Selbstmontage.
<b>Zusatzabstützung seitlich</b>	Zum Aufrichten langer Auslegersysteme.
<b>Gegengewichtswagen</b>	Antrieb 4 x 4, zulässiges Gesamtgewicht 320 t, Eigengewicht 40 t, in Verbindung mit Teleskop-SL-Einrichtung.
<b>Quick-connection</b>	Hydraulische Schnellverbindung Unterwagen/Oberwagen zur Reduzierung der Transportgewichte.
<b>Bodenplatten</b>	2000 mm.
<b>Quadro-Antrieb</b>	Zusätzlich zwei Planetengetriebe an den Raupenträgern zur Verdopplung der Vortriebskräfte. Dabei reduziert sich die Fahrgeschwindigkeit entsprechend.

**TECHNISCHE BESCHREIBUNG**

**AUSLEGERVARIANTEN S UND L**

<b>SH:</b>	Hauptausleger: Fußstück 10,5 m (geeignet zum Einbau der Winde W1/H3), Zwischenstücke 12 m und 6 m (Typ 2724) und Reduzierstück 12 m, Kopf mit Rollensatz 600 t 1,5 m. Hauptauslegerlängen: 24-84 m.
<b>SH / LH:</b>	Hauptausleger: wie SH, verlängert mit Typ 2421 aus Hilfsausleger und Spitze 7,5 m. Hauptauslegerlängen: 66-102 m.
<b>SW:</b>	Hauptausleger: wie SH. Hilfsausleger: Fußstück 4,5 m, Zwischenstücke 12 m und 6 m (Typ 2421) und Spitze 7,5 m. Hauptauslegerlängen: 30-66 m. Hilfsauslegerlängen: 24-84 m.
<b>SSL:</b>	Hauptausleger: wie SH. Superlift-Einrichtung, Superliftgegengewicht 0-300 t (Stufung 50 t). Hauptauslegerlängen: 36-84 m.
<b>HSSL:</b>	Hauptausleger: wie SH / SSL + Hauptausleger-Verstärkungs-Kit. Superlift-Einrichtung, Superliftgegengewicht 0-300 t (Stufung 50 t). Hauptauslegerlängen: 54-108 m.
<b>SSL / LSL:</b>	Hauptausleger: wie SH 84 m, verlängert mit Typ 2421 aus Hilfsausleger und Spitze 7,5 m. Superlift-Einrichtung, Superliftgegengewicht 0-300 t (Stufung 50 t). Hauptauslegerlängen: 90-138 m.
<b>SWSL: (SFSL)</b>	Hauptausleger: wie SH. Hilfsausleger: wie SW. Superlift-Einrichtung, Superliftgegengewicht 0-300 t (Stufung 50 t). Hauptauslegerlängen: 36-84 m. Hilfsauslegerlängen: 24-84 m.
<b>HSWSL:</b>	Hauptausleger: wie HSSL. Hilfsausleger: wie SW/SWSL. Superlift-Einrichtung, Superliftgegengewicht 0-300 t (Stufung 50 t). Hauptauslegerlängen: 54-108 m. Hilfsauslegerlängen: 24-96 m.
<b>LF2:</b>	Hauptausleger: wie SH, SSL, HSSL, SH/LH, SH/LH SGLmax; SSL/LSL, SSL/LSL SGLmax. Hilfsauslegerlängen: 12, 24, 36 m. Hilfsausleger-Vorneigung: 10°, 15°, 20° für Hilfsauslegerlänge 12 m. Hilfsausleger-Vorneigung: 10°, 20°, 30° für Hilfsauslegerlängen 24-36 m.
<b>SFVL:</b>	Hauptausleger: wie SH, Längen 42-84 m, ohne Rollensatz. Hilfsausleger: Fußstück 4,5 m, Zwischenstück 6 m; Schwerlastkopf 1,5 m. Rollensatz 600 t wie SH.
<b>SH/LH SGLmax:</b>	Wie SH, verlängert um Hauptausleger-Verstärkungs-Kit + Hilfsausleger-Spitze. Hauptauslegerlängen: 78-108 m.
<b>SSL/LSL SGLmax:</b>	Wie SSL, verlängert um Hauptausleger-Verstärkungs-Kit + Hilfsausleger-Spitze. Hauptauslegerlängen: 90-138 m.
<b>Einscherwinde</b>	Auf Oberwagen angebaut.
<b>Sicherheitseinrichtungen</b>	Elektronischer Lastmomentbegrenzer, Hubendschalter, Endschalter für Auslegerbewegungen, hydraulische Ausleger-Rückfallsicherungen, Windmesser.

**ZUSATZAUSRÜSTUNG**

<b>Hauptausleger-Verstärkungs-Kit</b>	Bestehend aus 2-4 zusätzlichen schweren Hauptauslegerstücken; Standard-Hauptausleger 84 m erforderlich.
<b>Superlift-Einrichtung Standard</b>	Mast 30 m, Winde mit Seil und Traverse für 300 t. Mastradien 11, 13 und 15 m, durch Verstellung der Mastposition.
<b>Superlift-Einrichtung Teleskopverstellung</b>	Mast 30 m, Winde mit Seil, Teleskopverbindung und Traverse für 300 t. Maststellung 15 m. Superlift-Gegengewicht verstellbar von 13 bis 17 m.
<b>Seilwinde H3</b>	Zusätzliche Seilwinde im Hauptausleger (zum Betrieb an LF2 oder Runner). Seilzug wie H1, Seillänge 650 m.
<b>Runner 30 t</b>	Ca. 2 m zum Anbau an Kopf oder Spitze (nicht in Verbindung mit LF2).
<b>Runner 60 t</b>	
<b>Auslegerteile hydraulisch verbolzbar</b>	



## DESCRIPTIF TECHNIQUE

### CHÂSSIS À CHENILLES

	Le châssis à chenilles consiste en trois parties – deux chenilles et la partie centrale. Les chenilles et la partie centrale sont verrouillées hydrauliquement facilitant ainsi le montage et démontage pour diminuer la largeur d'encombrement et le poids de transport.
<b>Partie centrale</b>	Construction mécano-soudée, rigide à la flexion et à la torsion, sous forme de caissons en acier de construction de haute résistance à grains fins.
<b>Chenilles</b>	Trains de chenille: construction mécano-soudée rigide à la flexion, réalisés en acier de construction de haute résistance à grains fins. Les patins des chenilles ainsi que les barbotins d'entraînement et les roues directrices sont en acier coulé de haute résistance, traité par trempe et revenu. Chaque chenille est équipée de 15 galets d'appui dont les surfaces de roulement sont trempées. Graissage centralisé automatique inclus de série.
<b>Entraînement</b>	Les barbotins sont entraînés par deux moteurs hydrauliques et réducteurs planétaires, sous bain d'huile, en carter étanche, munis de freins d'arrêt à commande par ressorts, desserrés hydrauliquement. Grâce à leur compacité, les réducteurs s'intègrent complètement dans la largeur des chenilles. Chaque chenille permet un mouvement individuel et opposé.
<b>Vérins de montage</b>	Quatre vérins hydrauliques sur la partie centrale (repliable sans excéder la largeur de 3 m) permettant le montage facile des chenilles.

### PARTIE SUPÉRIEURE

<b>Contrepoids</b>	160 t / 180 t optional en combinaison avec de lest central au châssis.
<b>Charpente</b>	Structure mécano-soudée, rigide à la torsion, réalisée en acier de construction de haute résistance à grains fins. Couronne d'orientation à trois rangées de rouleaux servant de jonction entre la partie tournante et le châssis.
<b>Moteur et transmission</b>	Moteur diesel DaimlerChrysler, type OM 502 LA, 390 kW (530 CV) à 1800 1/min, couple 2400 Nm à 1300 1/min. Le moteur satisfait aux règlements EUROMOT 3a, EPA T3 et Carb. Boîte de distribution à cinq pompes hydrauliques à débit variable du type à pistons axiaux ainsi que pompes à engrenages. Dispositif d'échappe avec pare-étincelles.
<b>Tambours</b>	L'équipement standard de la partie tournante comprend trois tambours – treuil no 1, treuil no 2 et mécanisme de relevage. Les tambours sont entraînés par des moteurs hydrauliques munis de réducteurs planétaires, sous bain d'huile, en carter étanche. Tous les tambours sont munis de freins à disques multiples, à commande par ressorts, et desserrés hydrauliquement. Freinage anti-usure hydraulique pour descendre la charge. Les pattes de câble H 1, 2, 3 et W 1, 2 sont équipées des attaches à jonction rapide. Treuils H 1 + 2 sont démontables pour diminuer le poids de transport.
<b>Chevalet</b>	Système de relevage hydraulique pour chevalet en série.
<b>Mécanisme d'orientation</b>	Entraîné par moteur hydraulique avec réducteur planétaire, sous bain d'huile, en carter étanche. Frein d'arrêt à commande par ressorts, desserré hydrauliquement ainsi que freinage anti-usure hydraulique.
<b>Commande</b>	Demag IC-1 : Pilotage électronique de soupapes proportionnels intégré dans un automate programmable avec diagnostic de dysfonctionnement. 2 écrans couleur, commande du C.E.C. par écran tactile. Les vitesses de travail sont réglées sans paliers par la position du levier. Régulation automatique pour une exploitation optimale de la puissance du moteur, commande d'urgence.
<b>Cabine</b>	Cabine confortable avec large pare-brise et climatisation. Vitrage de sécurité, fenêtre de toit, chauffage à air autonome, organes de commande et instruments de contrôle. Cabine inclinable en arrière assurant au grutier une visibilité optimale. Une caméra est installée pour la surveillance des treuils. Pendant le transport, la cabine est basculée à l'avant de la partie tournante.
<b>Installation électrique</b>	24 V courant continu. (2 x accumulateurs 12 V, 200 Ah).

### EQUIPEMENTS OPTIONNELS

<b>Contrepoids</b>	20 t sur la partie tournante (uniquement en combinaison avec lest central).
<b>Lest central</b>	60 t.
<b>Cylindre hydraulique pour le chevalet</b>	Pour le montage des trains de chenille.
<b>Stabilisateur latéral additionnel</b>	Pour le montage des flèches longues.
<b>Chariot contrepoids</b>	Entraînement 4 x 4, poids total 320 t, poids spécifique 40 t, en combinaison avec l'équipement Superlift télescopique.
<b>Connexion rapide</b>	Connexion rapide hydraulique entre châssis et partie tournante permettant le démontage facile pour réduire le poids de transport.
<b>Patins des chenilles</b>	2000 mm.
<b>Entraînement quadro</b>	Deux moteurs hydrauliques de plus, placées aux trains de chenille pour doubler les forces. La vitesse sur route est diminuée proportionnellement.



**DESCRIPTIF TECHNIQUE**

**CONFIGURATIONS DE FLÈCHE S ET L**

<b>SH:</b>	Flèche principale: pied 10,5 m (utilisé à installer treuils W1/H3), intercalaires 12 m et 6 m (type 2724) et tronçon conique 12 m, tête avec jeu de poulies 600 t 1,5 m. Longueurs de flèche principale: 24-84 m.
<b>SH / LH:</b>	Flèche principale: idem SH, allongée par type 2421 de la fléchette et par l'élément de pointe 7,5 m. Longueurs de flèche principale: 66-102 m.
<b>SW:</b>	Flèche principale: idem SH. Fléchette: pied 4,5 m, intercalaires 12 m et 6 m (type 2421) et élément de pointe 7,5 m. Longueurs de flèche principale: 30-66 m. Longueurs de fléchette: 24-84 m.
<b>SSL:</b>	Flèche principale: idem SH. Équipement Superlift, contrepoids Superlift 0-300 t (par progression de 50 t). Longueurs de flèche principale: 36-84 m.
<b>HSSL:</b>	Flèche principale: idem SH/SSL + kit à fortifier de flèche principale. Équipement Superlift, contrepoids Superlift 0-300 t (par progression de 50 t). Longueurs de flèche principale: 54-108 m.
<b>SSL / LSL:</b>	Flèche principale: idem SH 84 m, allongée par type 2421 de la fléchette et par l'élément de pointe 7,5 m. Équipement Superlift, contrepoids Superlift 0-300 t (par progression de 50 t). Longueurs de flèche principale: 90-138 m.
<b>SWSL: (SFSL)</b>	Flèche principale: idem SH. Fléchette: idem SW. Équipement Superlift, contrepoids Superlift 0-300 t (par progression de 50 t). Longueurs de flèche principale: 36-84 m. Longueurs de fléchette: 24-84 m.
<b>HSWSL:</b>	Flèche principale: idem HSSL. Fléchette: idem SW/SWSL. Équipement Superlift, contrepoids Superlift 0-300 t (par progression de 50 t). Longueurs de flèche principale: 54-108 m. Longueurs de fléchette: 24-96 m.
<b>LF2:</b>	Flèche principale: idem SH, SSL, HSSL, SH/LH, SH/LH SGLmax; SSL/LSL, SSL/LSL SGLmax. Longueurs de fléchette: 12, 24, 36 m. Inclinaison de fléchette: 10°, 15°, 20° pour longueur de fléchette 12 m. Inclinaison de fléchette: 10°, 20°, 30° pour longueurs de fléchette 24-36 m.
<b>SFVL:</b>	Flèche principale: idem SH, longueurs 42-84 m, sans jeu de poulies. Fléchette: pied 4,5 m, intercalaire 6 m; tête levages-lourds 1,5 m. Jeu de poulies 600 t idem SH.
<b>SH/LH SGLmax:</b>	Idem SH, allongée de kit à fortifier de flèche principale + élément de pointe de fléchette. Longueurs de flèche principale: 78-108 m.
<b>SSL/LSL SGLmax:</b>	Idem SSL, allongée de kit à fortifier de flèche principale + élément de pointe de fléchette. Longueurs de flèche principale: 90-138 m.
<b>Tambour de mouflage</b>	Monté sur la partie tournante.
<b>Sécurités</b>	Contrôleur d'état de charge électronique, contacteur de fin de course haut, limiteurs de mouvements de la flèche, retenues hydrauliques anti-basculement de la flèche, anémomètre.

**EQUIPEMENT OPTIONNEL**

<b>Kit à fortifier de flèche principale</b>	Consiste de 2-4 tronçons additionnelles de type flèche principale; flèche principale standard de 84 m nécessaire.
<b>Équipement Superlift standard</b>	Mât 30 m, treuil avec câble et traverse pour 300 t. Radii du mât 11, 13 et 15 m par inclinaison de la position du mât.
<b>Équipement Superlift télescopique</b>	Mât 30 m, treuil avec câble, jonction télescopique et traverse pour 300 t. Position du mât 15 m. Contrepoids Superlift réglable de 13 à 17 m.
<b>Treuil H3</b>	Tambour supplémentaire sur la flèche principale (à utiliser avec LF2 ou runner). Effort au brin simple idem H1, longueur de câble 650 m.
<b>Runner 30 t</b>	Environ 2 m à installer en tête de flèche ou sur l'élément de pointe (pas en combinaison avec LF2).
<b>Runner 60 t</b>	
<b>Boulonnement hydraulique des intercalaires</b>	

**TRANSPORT EXAMPLE FOR CC 2800-1**  
**TRANSPORTBEISPIEL CC 2800-1**  
**EXEMPLE DE TRANSPORT POUR LA CC 2800-1**

Load approx. 82 t  
 Ladung ca. 82 t  
 Charge environ 82 t

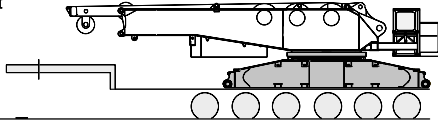

1x

Load approx. 22 t  
 Ladung ca. 22 t  
 Charge environ 22 t

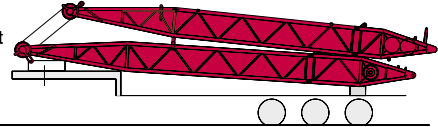

1x

Load 45 t  
 Ladung 45 t  
 Charge 45 t

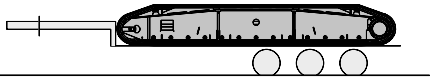

2x

Load 31 t  
 Ladung 31 t  
 Charge 31 t

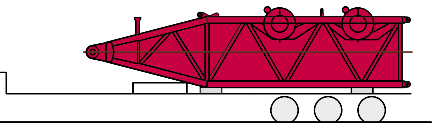

1x

Load 20 t  
 Ladung 20 t  
 Charge 20 t

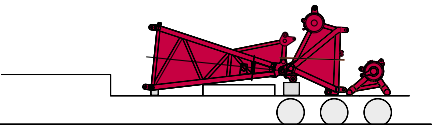

1x

Load 27 t  
 Ladung 27 t  
 Charge 27 t

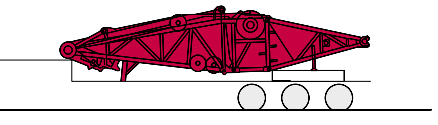

1x

Load 20,3 t  
 Ladung 20,3 t  
 Charge 20,3 t

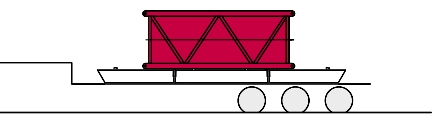

1x

Load 24,5 t  
 Ladung 24,5 t  
 Charge 24,5 t

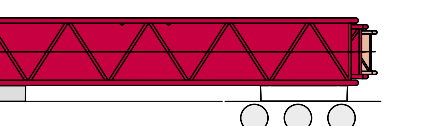

2x

Load 23,2 t  
 Ladung 23,2 t  
 Charge 23,2 t

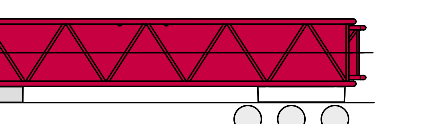

2x

- Superlift counterweight · Superlift-Gegengewicht · Contrepoids Superlift
- Basic crane · Grundgerät · Machine de base
- Boom combination · Auslegerkombination · Combinaison de flèche SWSL 84 + 84 m
- Containers, boxes, etc. · Container, Boxen, etc. · Conteneurs, boîtes, etc.
- Boom combination · Auslegerkombination · Combinaison de flèche LF2 36 m
- Low-loader · Tieflader · Semi-remorque

Load approx. 15 t  
 Ladung ca. 15 t  
 Charge environ 15 t



1x

Load 30,3 t  
 Ladung 30,3 t  
 Charge 30,3 t

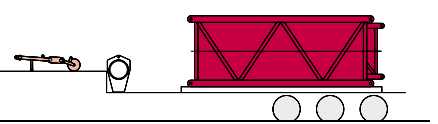

1x

Load 27 t  
 Ladung 27 t  
 Charge 27 t

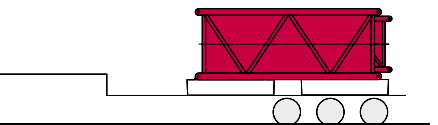

1x

Load 28,8 t  
 Ladung 28,8 t  
 Charge 28,8 t

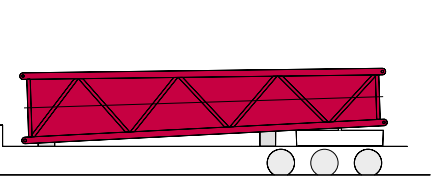

1x

Load 34,5 t  
 Ladung 34,5 t  
 Charge 34,5 t

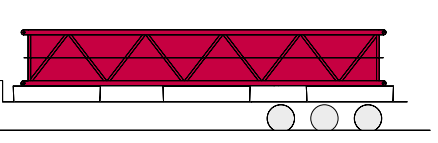

2x

Load 27,0 t  
 Ladung 27,0 t  
 Charge 27,0 t

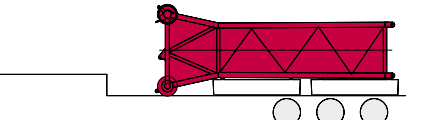

1x

Load 33,5 t  
 Ladung 33,5 t  
 Charge 33,5 t

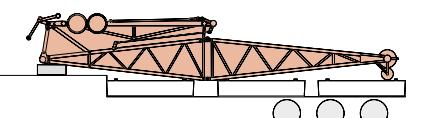

1x

90 t Superlift counterweight can be transported together with the complete SWSL attachment 84 m + 84 m + 36 m LF2. Depending on the load case, the remaining 210 t Superlift counterweight and some mats as required, will have to be carried on separate low-loaders.

Mit der gesamten Einrichtung SWSL 84 m + 84 m + 36 m LF2 lassen sich auch noch 90 t Superlift-Gegengewicht mitnehmen. Je nach Lastfall erfordern die restlichen 210 t Superlift-Gegengewicht sowie einige Unterleg-Matten weitere Tieflader.

90 t de contrepoids Superlift peuvent être transportés avec l'équipement SWSL 84 m + 84 m + 36 m LF2 tout ensemble. Les 210 t résiduelles du contrepoids Superlift ainsi que quelques plaques de calage, telles que nécessaires en fonction du cas de levage, seront à transporter sur des semi-remorques supplémentaires.

**NOTES TO LIFTING CAPACITY · ANMERKUNGEN ZU DEN TRAGFÄHIGKEITEN ·  
CONDITIONS D'UTILISATION**

Ratings are in compliance with ISO 4305 and DIN 15019.2 (test load = 1.25 x suspended load + 0.1 x dead weight of boom head).  
Weight of hook blocks and slings is part of the load, and is to be deducted from the capacity ratings.

Consult operation manual for further details.

**Note:** Data published herein is intended as a guide only and shall not be construed to warrant applicability for lifting purposes.  
Crane operation is subject to the computer charts and operation manual both supplied with the crane.

In some instances the superlift counterweight does not lift off the ground with the indicated load.

Tragfähigkeiten entsprechen ISO 4305 und DIN 15019.2 (Prüflast = 1,25 x Hublast + 0,1 x Kopfgewicht).

Das Gewicht der Unterflaschen, sowie die Lastaufnahmemittel, sind Bestandteile der Last und sind von den Tragfähigkeitsangaben abzuziehen.

Weitere Angaben in der Bedienungsanleitung des Kranes.

**Anmerkung:** Die Daten dieser Broschüre dienen nur zur allgemeinen Information; für ihre Richtigkeit übernehmen wir keine Haftung.  
Der Betrieb des Kranes ist nur mit den Original-Tragfähigkeitstabellen und mit der Bedienungsanleitung zulässig, die mit dem Kran mitgeliefert werden.

In einigen Fällen hebt das Superliftgegengewicht bei den angegebenen Traglasten nicht ab.

Le tableau de charges est conforme à la norme ISO 4305 et DIN 15019.2 (charge d'essai = 1,25 x charge suspendue + 0,1 x poids de la tête de flèche).

Les poids du crochet-moufle et de tous les accessoires d'élingage font partie de la charge et sont à déduire des charges indiquées.

Pour plus de détails consulter la notice d'utilisation de la grue.

**Nota:** Les renseignements ci-inclus sont donnés à titre indicatif et ne représentent aucune garantie d'utilisation pour les opérations de levage.  
La mise en service de la grue n'est autorisée qu'à condition que les tableaux de charges ainsi que le manuel de service, tels que fournis avec la grue, soient observés.

Le contrepoids du superlift ne décolle pas dans certaines configurations des tableaux de charge.





The information contained in this brochure / product catalogue merely consists of general descriptions and a broad compilation of performance features which might not apply precisely as described under specific application conditions or which may change as a result of further product development.

The desired performance features only become binding once expressly agreed in the final contract.

Subject to change without notice!

Die Informationen in dieser Broschüre / diesem Produktkatalog enthalten lediglich allgemeine Beschreibungen bzw. Leistungsmerkmale, die im konkreten Anwendungsfall nicht immer in der beschriebenen Form zutreffen bzw. die sich durch Weiterentwicklung der Produkte ändern können.

Die gewünschten Leistungsmerkmale sind nur dann verbindlich, wenn sie bei Vertragsabschluss ausdrücklich vereinbart werden.

Änderungen vorbehalten!

Les informations figurant dans la présente brochure / le présent catalogue de produit sont de simples descriptions ou des caractéristiques de performances générales qui ne correspondent pas toujours à la forme décrite dans le cas d'applications spécifiques concrètes ou qui peuvent varier en fonction des perfectionnements apportés aux produits.

Seules les caractéristiques de performances expressément convenues à la signature du contrat engagent notre société.

Sous réserve de modification!

03/06